

THIS IS ROCKET SCIENCE

IT IS FOR EVERYONE...

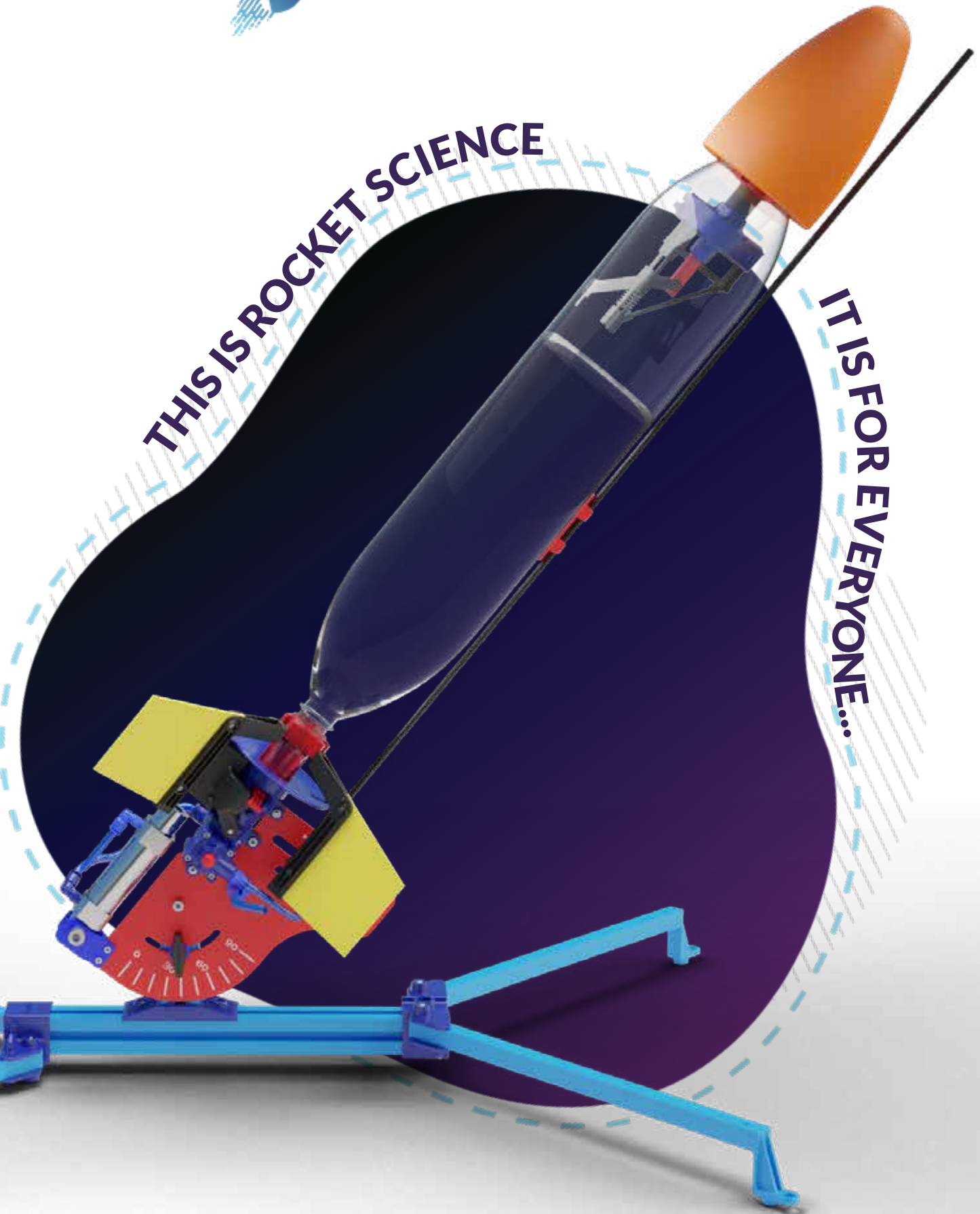

CONTENTS

| | | |
|---|---|----|
| ● | Why HydroLaunch® Water Rocketry System? | 7 |
| ● | Safety First | 8 |
| ● | Water Rocketry 2.0 | 12 |
| | HydroLaunch® Water Rocket System Components | |
| | HydroLaunch® Water Rocket Launcher | |
| ● | Water Rocket Construction | 20 |
| | Rocket Engine - PET or SODA Bottle | |
| | Making Fins & Rocket Nozzle Assembly | |
| | Your first Water Rocket | |
| | Adding the Elev8Eject - the parachute eject mechanism | |
| | Building a Parachute | |
| | Packing a Parachute | |
| | HydroLaunch Nose Cone | |
| ● | Water Rocket Stability | 42 |
| | Identifying the Center of Mass | |
| | Center of Pressure | |
| | Estimating the position of the Center of Pressure | |
| ● | Preparing for flight | 48 |
| | HYDROLAUNCH® WATER ROCKET LOG SHEET | |
| | Preparation Checklist: | |

| | | |
|---|---------------------------------|----|
| ● | Launching | 52 |
| | Launch Area & Safety | |
| | Preparing the Rocket & Launcher | |
| | Rocket on the Launcher | |
| | Pressurizing the Rocket | |
| | Launching the rocket | |
| | Preparing the Rocket & Launcher | |
| | Rocket on the Launcher | |
| | Pressurizing the Rocket | |
| | Launching the rocket | |
| | Recovery | |
| ● | NAR Safety Code | 58 |
| ● | Troubleshooting | 60 |
| ● | Bibliography | 64 |





HydroLaunch[®] Water Rocket System

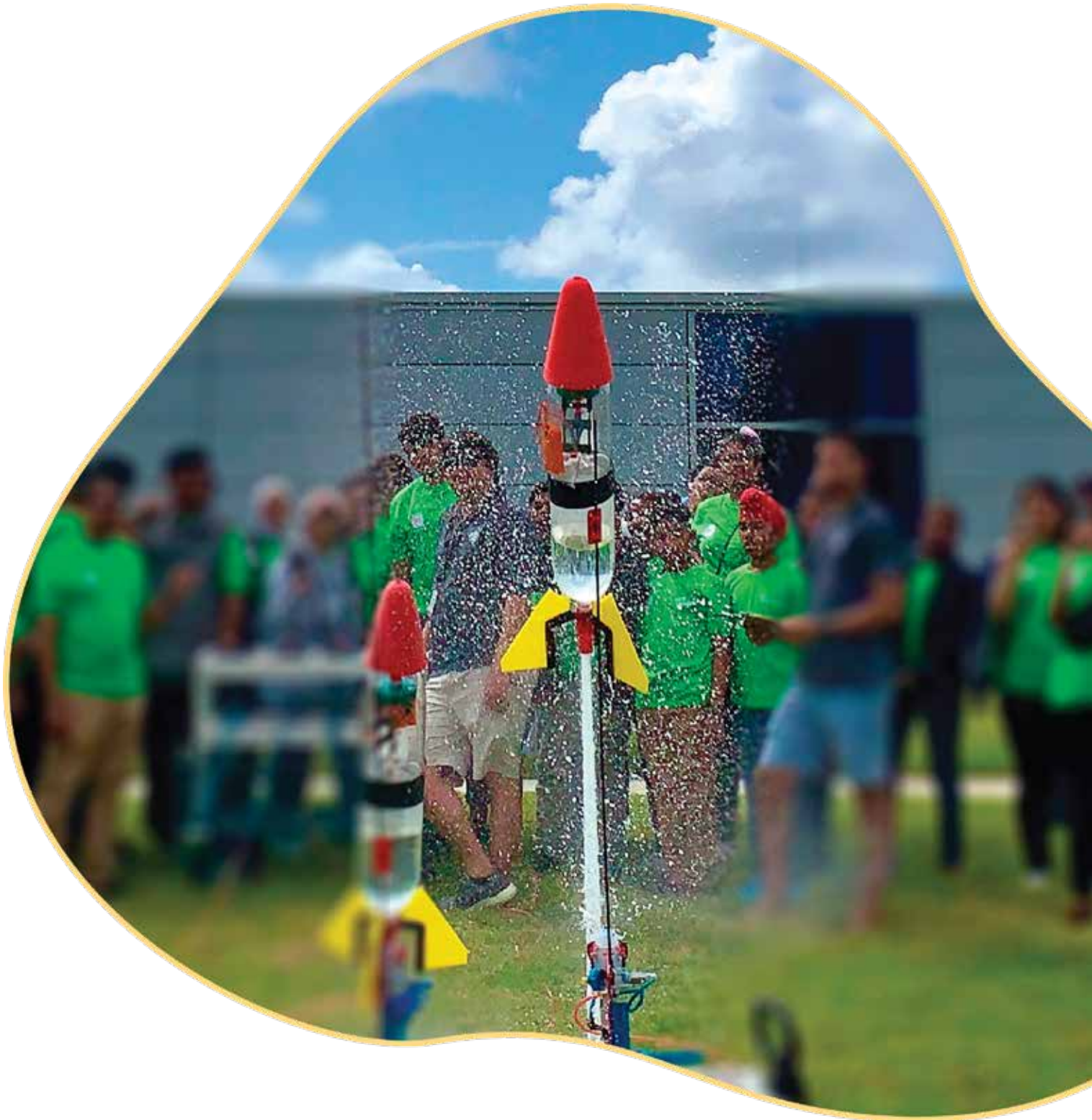

**It is Rocket Science &
It is for everyone!**

Why HydroLaunch® Water Rocketry System?

A simple water rocket is an inverted (upside down) soda bottle, which has a nose cone and fins added to it. The HydroLaunch® Water Rocket system brings a host of features and possibilities that make it the right tool for an advanced S.T.E.M. education. These features include:

- Variable thrust profile
- Low fin attachment
- Easy no-spill loading
- Adjustable launch angles
- A safety purge button for launch abort
- Launch Guide for stability
- Detachable fins
- Bottle Engine Test Apparatus for profiling rocket engine performance
- Elev8Eject - the parachute eject mechanism
- Software package that simulates rocket performance and trajectory
- LaunchTrak Altimeter for recording rocket flight

HydroLaunch® is the perfect S.T.E.M.* companion for students, teachers, and enthusiasts. The HydroLaunch® Water Rocket system converts a simple soda bottle into the ultimate teaching tool and offers the most versatile water rocket experience. We call it WATER ROCKETRY 2.0.



Safety First

Water Rocketry is considered a safe activity. The minimal risks and hazards involved in building and launching water rockets are mitigated by taking proper precautions to ensure safety during the activity

The Rocket Engine (PET bottle) :

The rocket engine is made up of Polyethylene terephthalate, or PET in short. It is a thermoplastic polyester resin designed for one cycle of pressurization. Each time you pressurize a PET bottle, they stretch a little. Multiple cycles of pressurization and depressurization cause fatigue and can lead to accidents.

It should be expected that with multiple uses, the bottle's strength will decrease over time.

Each time you fly and land, you may 'kink' the bottle. This discontinuity is like a mini crack that will cause premature failure at the kinked location during pressurization for future flights. Therefore, inspection of each bottle is important between flights.

Pressurization:

During launching and testing, the HydroLaunch® Water Rocket System will be pressurized and various parts of the system will experience large forces. As long as the pressurization limits set in this document are followed, outright failure of components is extremely unlikely. It is common though, for fittings to come loose, thus leading to pressure leaks.

When your launch system is pressurized, it should be treated like an unexploded firework. In particular, you should keep small children away and maintain a distance of at least 10 meters away from the launcher. Safety goggles and earplugs, or ear defenders, should be worn while the launcher is pressurized.

Pressure Limits :

We have a strict recommendation – never pressurize the HydroLaunch® Water Rockets to more than 90 psi (6.2 bar or 620 kPa). When you are using your HydroLaunch® water rocket system, keep the following in mind:

- Use only PET bottles that are designed for pressurized SODA water.
- Do not use PET bottles that have kinks or any visible damage on them, or they have thin walls and demonstrate visible expansion during initial stages of pressurization. Alternately, buying PET bottles designed for water rockets from suppliers like PITSCO is an option.

Knives, blades and sharp objects:

While building a water rocket, one is expected to use sharp knives, blades or scissors, and this presents a potential for accidents to happen, especially if children are present. The following precautions should be taken:

- Always cut away from your fingers and body
- When not in use, always cover the sharp surface of the blade with a manufacturer's cover, foam, or a cork.

Rocket Design :

Do not use any sharp points on either the nose cone or the fins. Never use metal fixtures or fittings on the external body of the rocket. The rocket should always have soft edges, and made with soft material ensuring safe handling.

Rocket Launch :

Avoid launching rockets in areas where people or animals are present. A water rocket launched at an angle or during wind, could land up to 100 meters away representing something of a challenge in any public access space!

- Please pick your spot carefully: most public parks are suitable for the shortest flights.
- Launch in a team, with one designated team member in-charge of ensuring everyone's safety. They should look out for people wandering into the firing range.
- Begin by firing at low pressures until you become familiar with your launch system and your surroundings. Remember that an accidental launch of the rocket is a real possibility, whenever the rocket is pressurized.
- Wind is an important factor while launching water rockets, and understanding the impact of wind on your rocket's flight is important for both a safe rocketry experience and the learning involved.
- Do not launch with children playing nearby.
- Ensure that any persons nearby are aware of the rocket launch before you pressurize and release.

The incorporation of the Model Rocket Safety Code provides guidelines for the safe operation of model rockets, such as launching the rockets electrically from a safe distance, which is replicated by the Pneumatic Launch System of the HydroLaunch®, and using Parachute Eject Mechanism to gently return the model water rocket to Earth. When the safety code is followed, model rocketry is an extremely safe activity.

General Precautions :

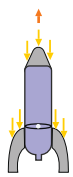

10 m



25 m

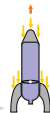

Dos:

- YOU MUST WEAR SAFETY GLASSES DURING ALL WATER ROCKET ACTIVITIES
- Once the rocket is pressurized, maintain a distance of at least 10 meters.
- The PET bottle used for the rocket engine must be free of kinks, cuts, or scratches that may affect the integrity of the bottle. Do not use damaged or warped pressurized PET Bottles.
- Select an open field or recreation area that is well away from other people, main roads, or highways.
- Avoid trees and powerlines - they have been responsible for numerous model rockets failing to return to the ground!
- An area the size of a football field will suffice for launching your rockets.
- Before the launch, check wind direction and adjust trajectory.
- Always advise onlookers of your intention to launch. Make a loud countdown before launch and ensure the public in your vicinity is aware of your activities.
- After every launch, check the parachute system for damage or malfunction.

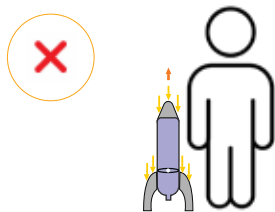
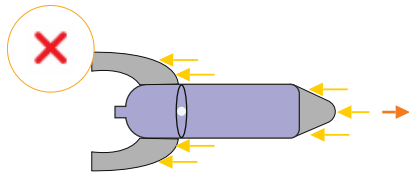

Don'ts:

- Do not launch rockets near sensitive facilities such as airports, power stations, electrical facilities, railway lines, car-parks, military installations, public amenities, roads, or highways.
- Do not launch rockets horizontally. Launch angles should not be less than 45 degrees with the horizontal.
- Do not put any part of your body in front of a pressurized rocket at any time.
- Do not over-pressurize the rocket. The maximum recommended pressure for launch is 90psi or 6.2bar.
- Do not overfill the rocket with water. The maximum recommended rocket fill is 50% of the bottles volume with a 45% fill being the most efficient engine.
- Do not launch rockets inside buildings or from under any potential obstruction such as trees or overhanging obstacles.

Water Rocketry 2.0

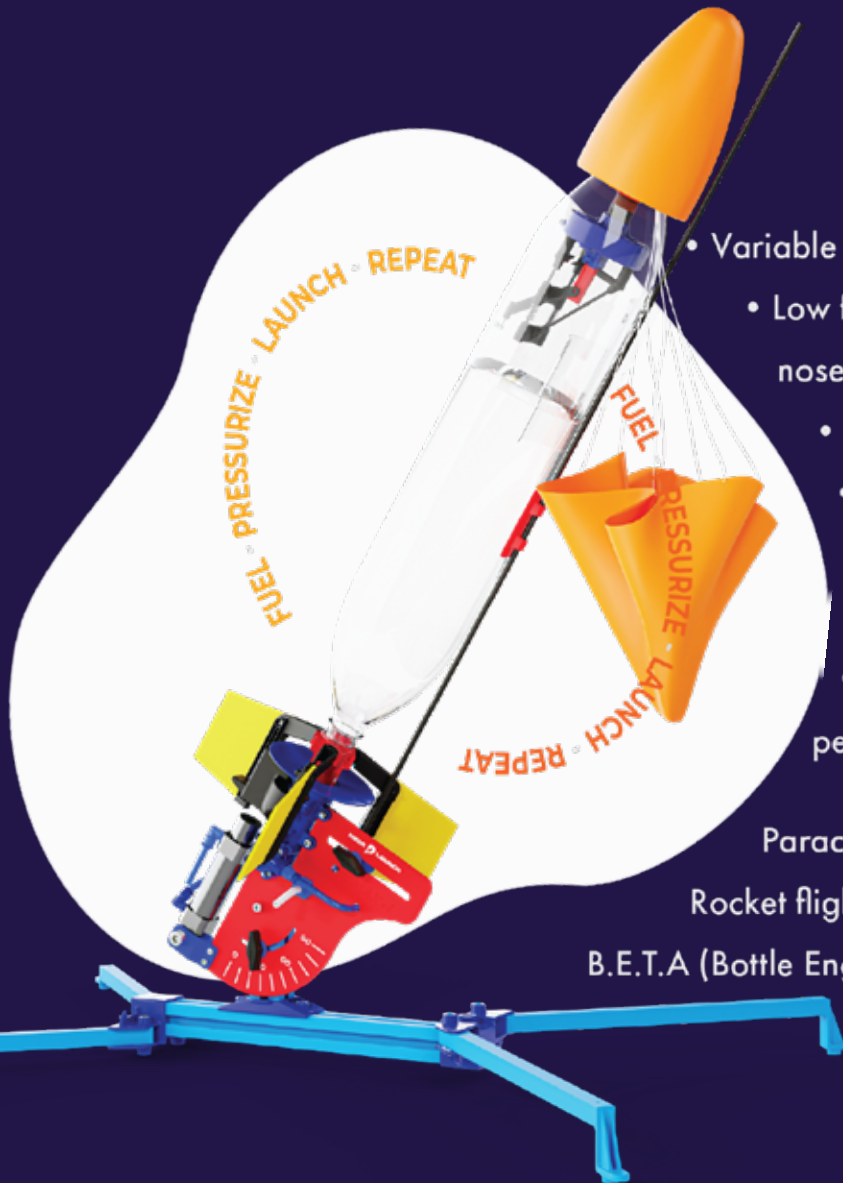

- Variable thrust profiles
- Low fin attachment and nose mounted payload bay
 - Launch angle adjustment
 - Easy no spill loading
 - Launch Guide for stability
 - A safety purge button for launch abort
 - Software package that simulates rocket performance and trajectory

Parachute Eject Mechanism

Rocket flight computer (Ultimeter)

B.E.T.A (Bottle Engine Test Apparatus)

Water Rocketry is inherently a safe activity. However, there are some risks and hazards associated with building and launching water rockets, taking precautions will keep you safe.

Typical model rockets use a combustion-based engine which involves potential fire hazard to the user and participants. Model rockets require a level of safety, preparation, and range management for their flight. On the other hand, water rockets store their energy in the form of compressed air rather than a combustible fuel. This makes them more suited for educational purposes.

By using water rockets to teach physics and engineering, teachers can utilize a natural excitement held in students of all ages. However, most water rocket systems are poorly suited for teaching. They have limited adjustments, an inability to control parameters, and they only allow experimentation through actual flights. To be a true teaching tool, the device must provide students a chance to control outcomes, predict future outcomes, and replicate experimental data. Keeping all this in mind, let's enter the world of Water Rocketry 2.0 with the HydroLaunch® Water Rocket System.

The HydroLaunch® Water Rocket system enhances the traditional method of using pressurized water to propel a rocket by transforming it into a powerful teaching tool. This system introduces mechanical complexity, enabling students to engage in hands-on engineering of a water rocket. Through this process, they can customize launch angle, nozzle size, and deploy a parachute with precision. The foam nosecone of the rocket contains a space for the LaunchTrak flight computer, which records and provides students with detailed flight data. Students can analyze the logged data, including flight altitude and graphing. Additionally, the Hydro Launch system includes the B.E.T.A. (Bottle Engine Test Apparatus), a new tool for measuring thrust and enabling students to predict rocket flight in the classroom. Water Rocketry 2.0 not only offers a thrilling and enjoyable experience, but also serves as a valuable tool for students to conduct experiments, analyze data, and improve their mechanical

skills through hands-on learning. By allowing students to learn the material without compromising the science, Water Rocketry 2.0 provides an excellent approach to education. Incorporating Water Rocketry 2.0 into your lesson plans can make a significant impact and add a splash of excitement.

The system has been meticulously crafted from the ground up with the latest STEM education standards in mind. It empowers learners to conduct activities such as testing rocket engines like NASA scientists, manipulating variables, collecting and analyzing data, making predictions and launching rockets. The hardware, software and curriculum support are all geared towards helping learners to become confident and skilled scientists and engineers.

HydroLaunch® Water Rocket System Components

Unlike other Water Rockets available on the market, the HydroLaunch® is a complete system that provides all the features expected in a model rocket - from an aerodynamic nose cone to precision cut fins, all you need are a couple of soda bottles for your next rocketry adventure.

1. Rocket Nozzle and Fin Assembly
2. Rocket Engine (Soda Bottle)
3. Launch Guide
4. Launch Rod
5. Fuselage
6. Nose Cone
7. Elev8Eject - Parachute Eject Mechanism
8. Parachute
9. Hydrolaunch® Water Rocket Launcher

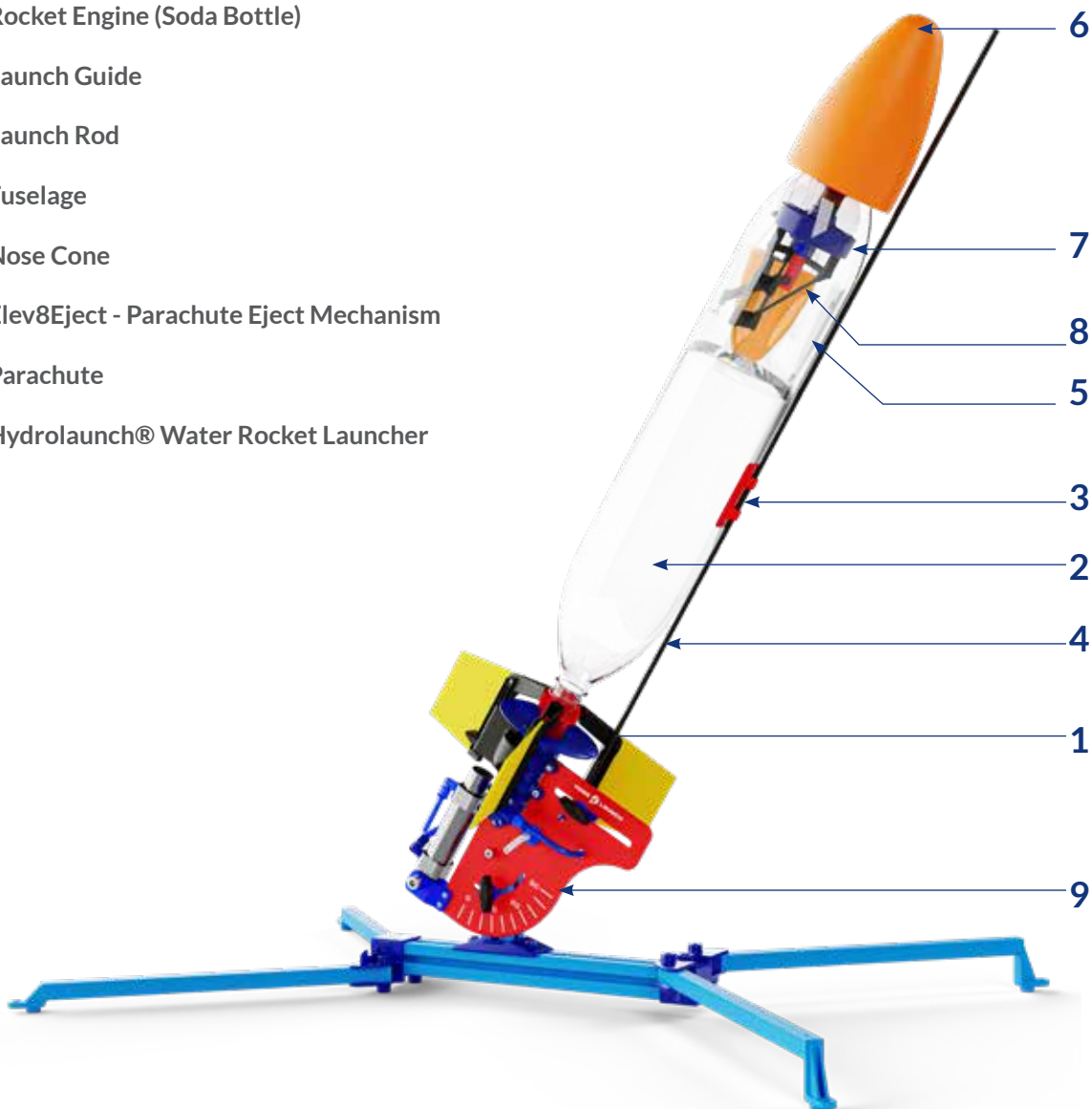

HydroLaunch® Water Rocket System Components

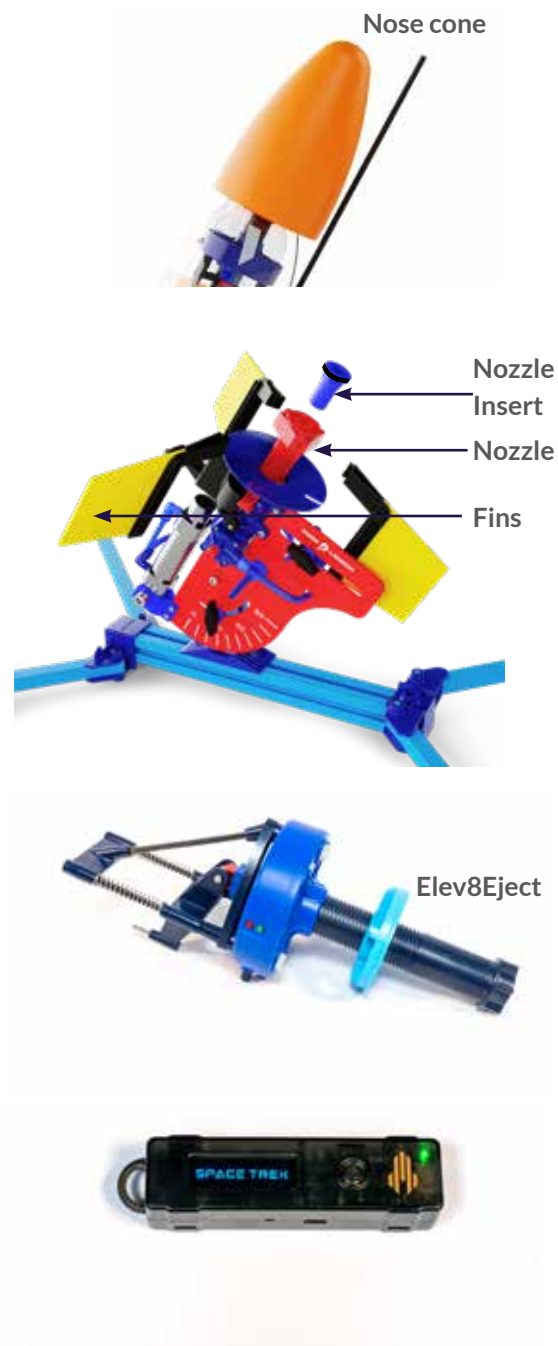

A HydroLaunch® Water Rocket typically consists of:

HydroLaunch® Nose Cone - A polyurethane nose cone weighing just 80 grams to make your water rocket aerodynamic. Specially designed to house the LaunchTrak, this nose cone adds advanced capabilities to your water rocket.

Nozzle - Threads mated with standard soda bottles, and slots for low profile detachable fins, these rocket nozzles enable you to make a variety of rockets with different size soda bottles.

Nozzle Inserts - 8mm, 10mm and 12mm standard inserts come in your HydroLaunch® water rocket kit, enabling you to experiment with a variety of thrust profiles.

Fins - Low-profile detachable fin holders compatible with the nozzle enable you to use either the standard fins (included in the HydroLaunch® kit) or build your own with our simple guide.

Elev8Eject - The parachute eject mechanism uses a tilt switch to deploy parachutes at apogee, with 0° to 45° launch angles from the vertical.

LaunchTrak Altimeter - The most sophisticated instant flight analysis tool for measuring the performance of your rocket. At 14gms, it is extremely lightweight, and provides more than 10 vital measurements including max altitude, top speed, peak acceleration, engine thrust duration, time to apogee, total flight time, and force on impact with the ground.

HydroLaunch® Water Rocket Launcher

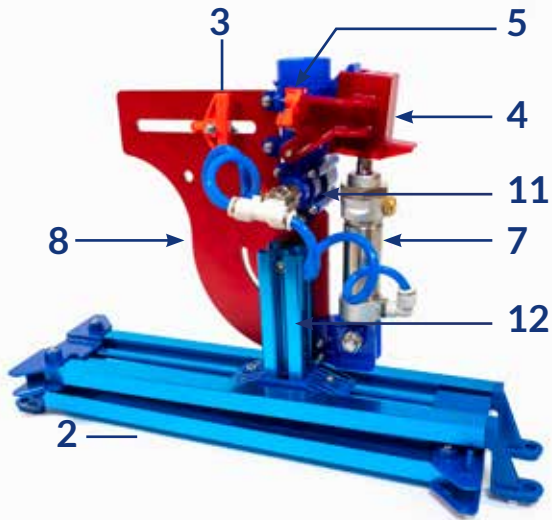

A HydroLaunch® Water Rocket Launcher

1. Nozzle Housing
2. Adjustable Legs
3. Launch Rod Holder
4. Lock Catch
5. Trigger Latch
6. Emergency Purge Button
7. Pneumatic Release Piston / Trigger Piston
8. Launcher Face Plate
9. Pressure Input / Inlet
10. Launch Angle Adjustment
11. Check Valve Assembly
12. Vertical Support Beam

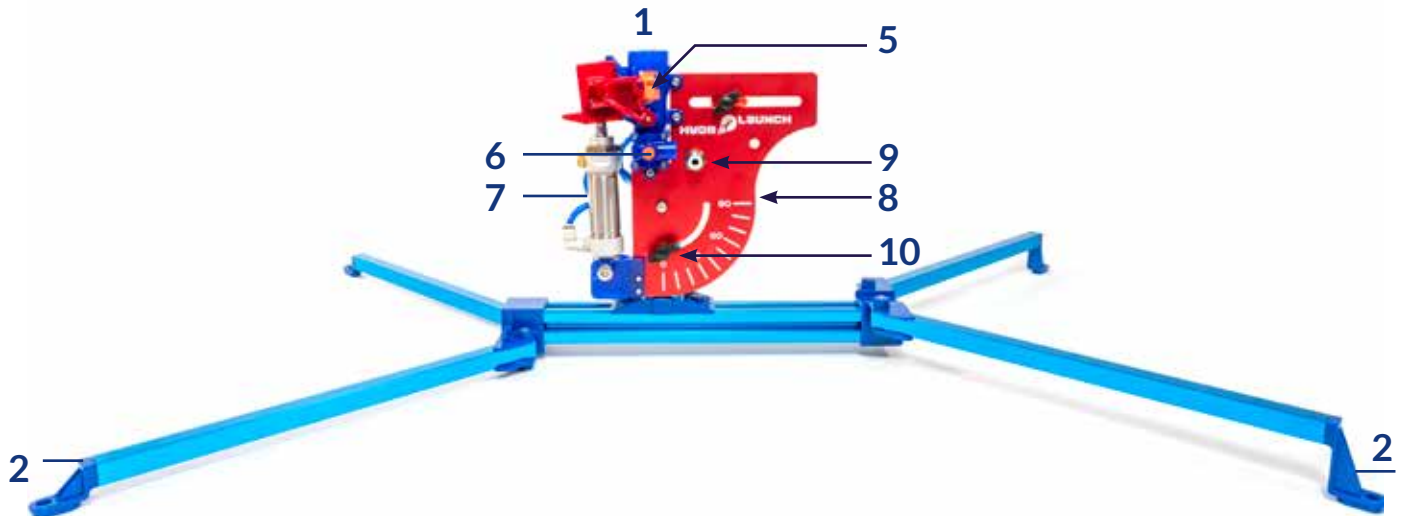

Rocket Parts:

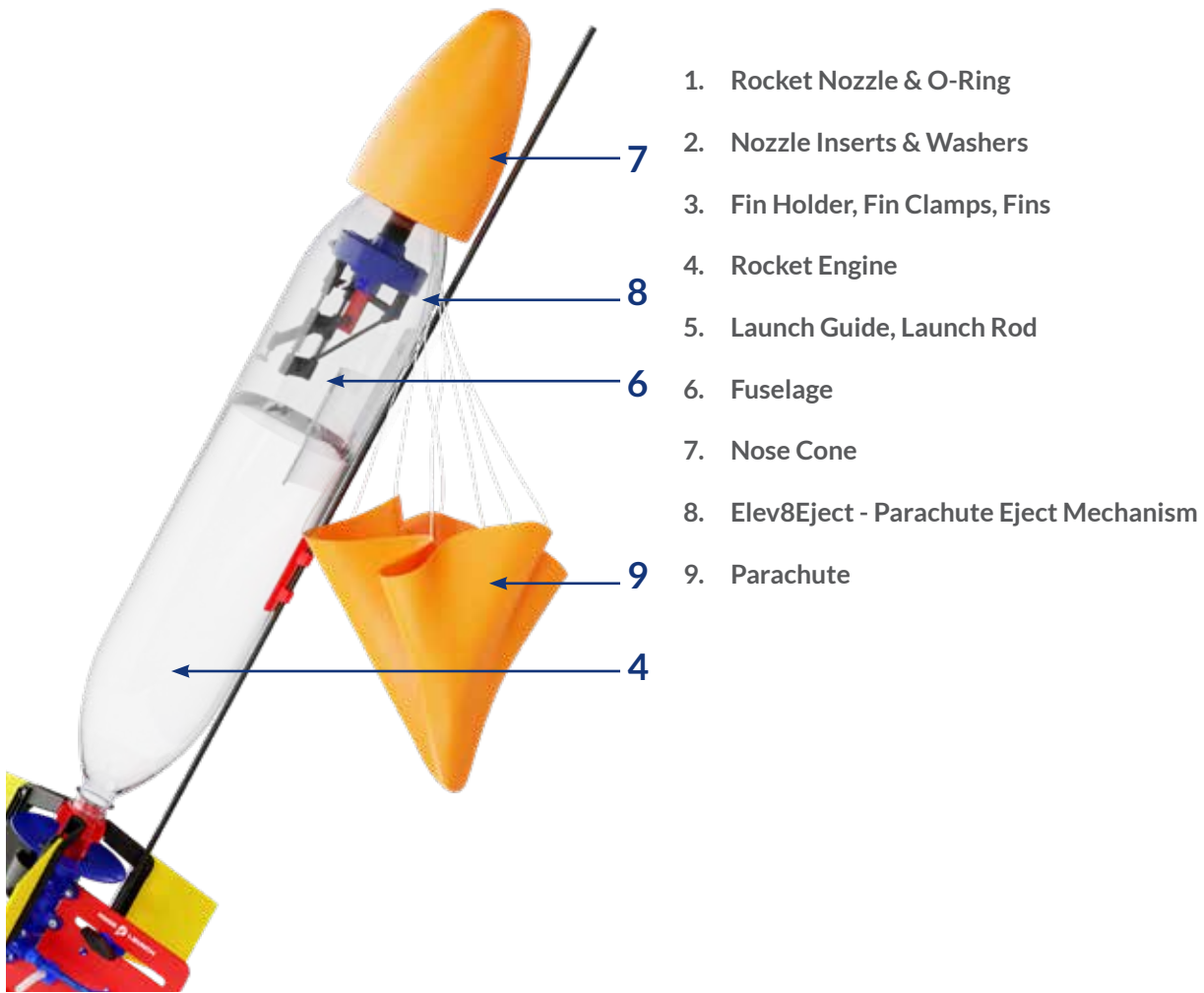

1. Nozzle



2. Nozzle Insert



3. Fin Holder, Fin Clamps, Fins



5. Launch Guide & Launch Rod

Elev8Eject - Parachute Eject Mechanism



1. Eject Holder Shaft
2. Lock Slider
3. Plunger
4. On/Off Button
5. Eject Clamp
6. Slider Cage
7. LED Indicators
8. Charging Port

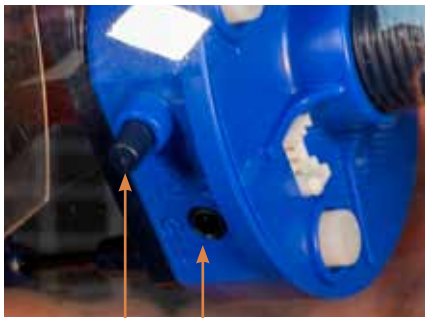

4 8



7

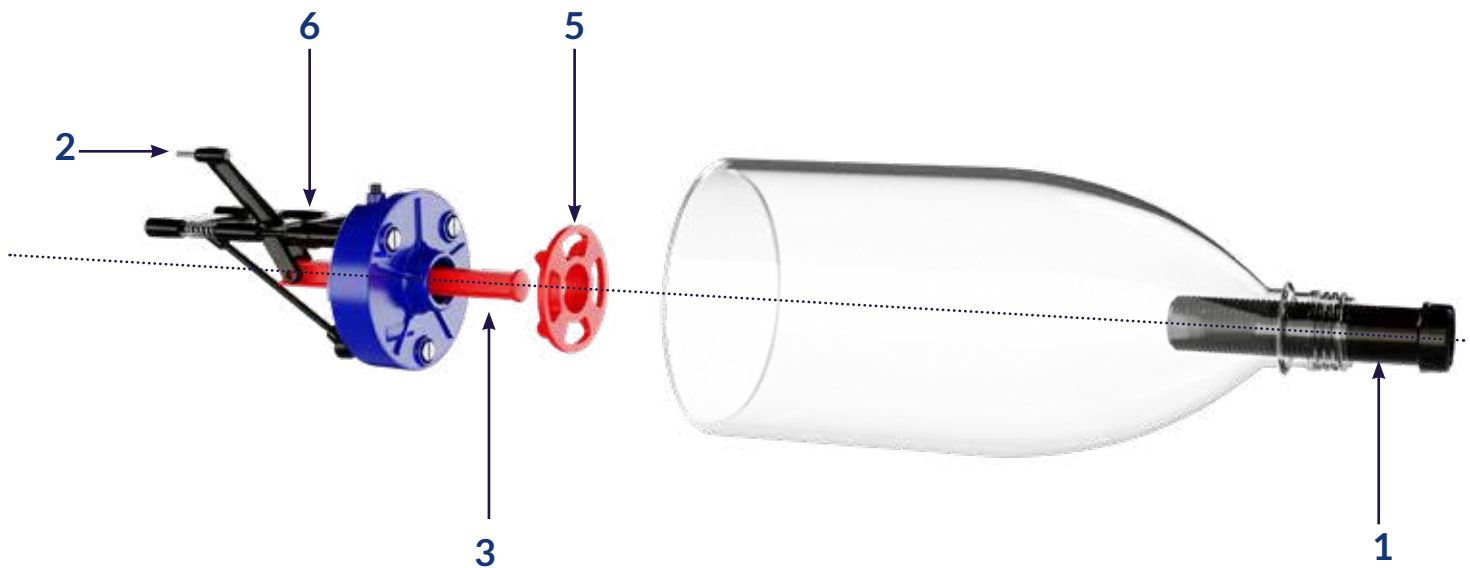

HydroLaunch® Water Rocket Launcher

The HydroLaunch® Water Rocket Launcher is the first launch system to use compressed air for both pressurizing and launching the rocket. The same line is used to pressurize the rocket and arming the pneumatic piston, and through depressurization of the line, the rocket launch is triggered..

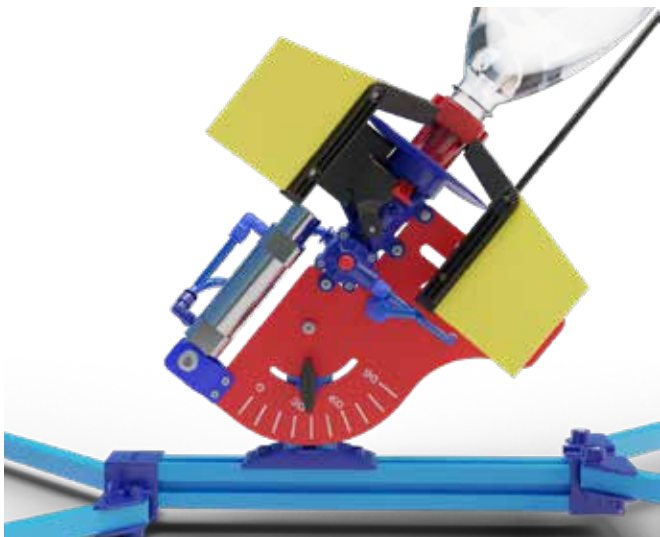

1. The angle launch system

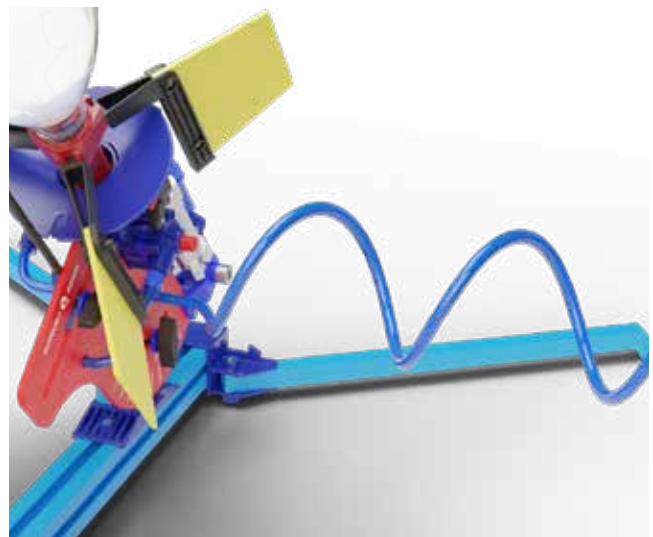

2. Pneumatic release system

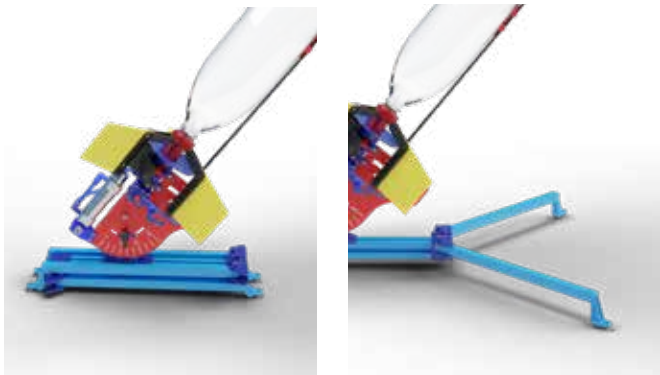

3. Feet opening and closing for stability



4. Adjustable Launch Rod and Launch Guide

Water Rocket Construction

- Rocket Engine- PET or SODA Bottle
- Making Fins & Rocket Nozzle Assembly
- Your First Water Rocket - Ballistic Rocket
- Installing Elev8Eject -the parachute eject mechanism
- Packing a Parachute
- Installing HydroLaunch® Nose Cone

Rocket Engine - PET or Soda Bottle



A wide range of soda bottles can be modified to make a water rocket. 500ml, 1 litre or 2 litre bottles are commonly available, and all standard soda bottles are compatible with the HydroLaunch® Rocket Nozzles. Inspecting the soda bottle for any physical damage, kink or crack of any kind is very important.

DO NOT use the same bottle as a rocket engine for more than 5 launches. Bottles used as rocket engines can be recycled as fuselage.

NEVER PRESSURIZE the rocket beyond 90 psi. If the PET bottle walls seem thin, it shouldn't be used as an engine.

Please ensure there are no crack lines on the soda bottle you are using.

Making Fins & Rocket Nozzle Assembly

Step

1

Check the (engine) bottle for any kinks or cracks.



Step

2

2.1 Install the (detachable, prebuilt) fins.

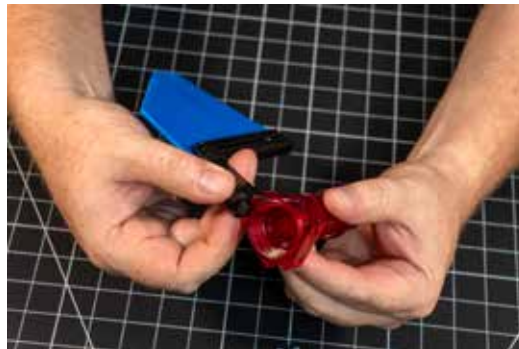

2.2



2.3



Step

3

Insert a nozzle insert of your choosing and screw the nozzle on the bottle (engine).

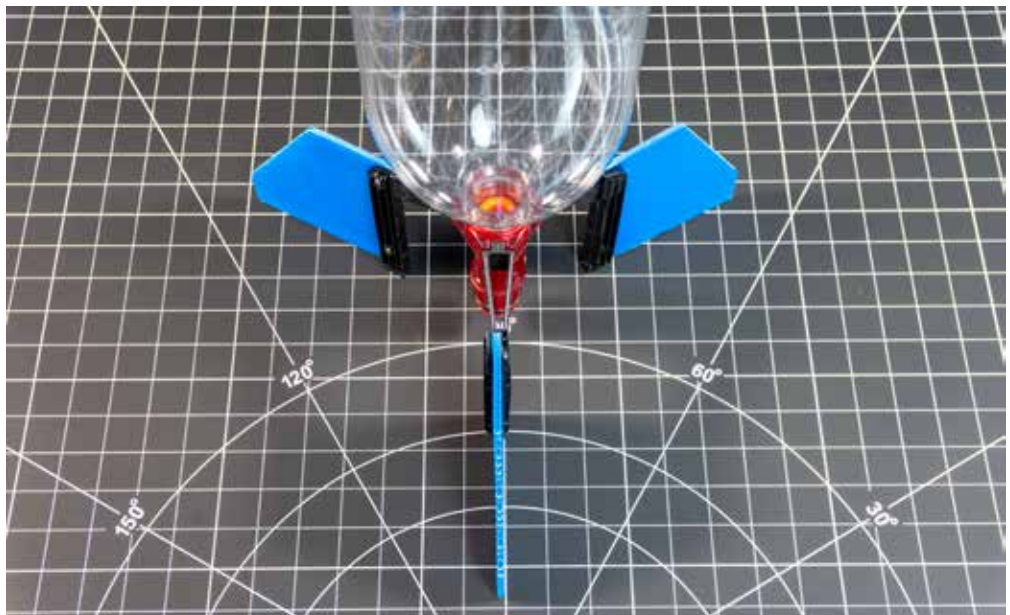

Fins & Rocket Nozzle Assembly is Ready !

DIY

In case you decide to design custom fins, follow the steps below

Materials Required:

1. Safety Goggles
2. Corrugated plastic sheet or similar lightweight
3. Plastic sheets (1.5 to 3mm thickness)
4. 1x Rocket Nozzle, and inserts (8mm, 10mm or 12mm)
5. 3x Fin Holder and Clamp
6. 6x M2X6mm Screws
7. 1x 1.5mm Allen key
8. Box Cutter, Cutting mat and ruler

Instructions:

- Use the fin holder and clamp to cut fins of correct size. Try experimenting with different shapes and see if any changes to flight characteristics.
- Ensure the grain of the plastic sheet is roughly at right angles to the clamp.
- Install fins using the fin clamp and the two M2 X 6mm screws provided.
- Repeat process for the 2 other fins.
- Push the 3 assembled fins into the slots on the nozzle.

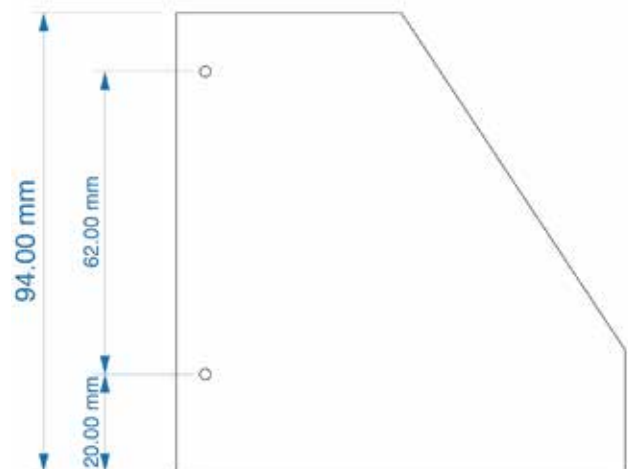

Your first Water Rocket - Ballistic Rocket

We will build a ballistic water rocket - the simplest and quickest to build. It includes the engine and nozzle assembly we built in the previous step along with a fuselage and nose cone.

Materials Required:

1. Safety goggles
2. 1x PET soda bottle for fuselage (this can be a recycled rocket engine bottle)
3. 1x PET soda bottle for rocket engine.
4. Duct Tape (or similar tape that is at least 1.5" wide)
5. Box Cutter or Precision Knife (XACTO), scissors and cutting mat
6. 1x Nose Cone

Building the fuselage using a PET (Soda) Bottle

The soda bottle used in this step should be the same size as the rocket engine, making it easier to join them together with (duct) tape.

Most soda bottles have a mold line at the base, if there is none, then you may want to draw a line going around the bottle at the base which will serve as your cutting line.

Carefully using a box cutter, make a small cut at this base line (large enough for your scissors to go through). Insert the scissors into the hole and continue cutting around the cutting line, till the base is completely removed.

Make sure the newly cut bottle fits on the top of the rocket engine. Trim as needed to create a good fit.

Attach as per the steps below:

Step

1



Step

2



Step

3

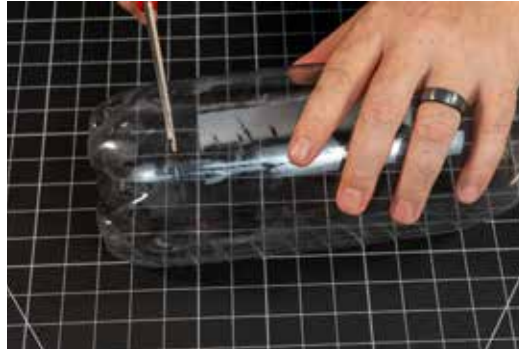

Step

4

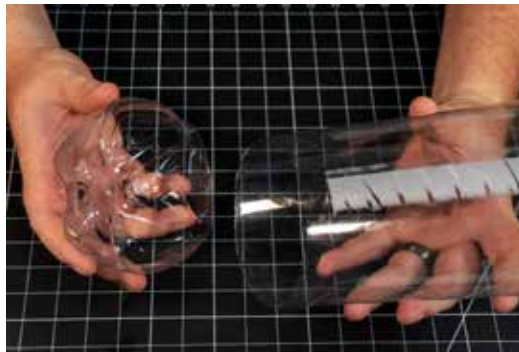

Step

5

Watch out for sheared edges on the cut bottle. Be careful of shards



Step

6

6.1 (Optional): To reinforce the bottle and eliminate its sharp edges, utilize a hot plate to melt and slightly curl the cut edge of the bottle.

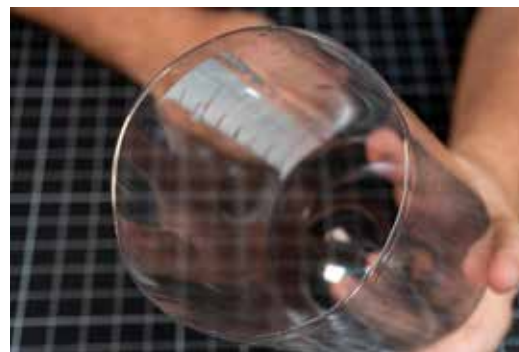

- 6.2 Do not overheat, it may result in overly curled. In case this happens, remove the bad edge and reheat.



NOTE: At this stage we can add clay to the top of the rocket to move the center of mass (gravity) towards the top of the rocket. You can use alternatives to clay to add weight - time to get creative.

Step

7

Use duct tape to connect the Engine with the fuselage

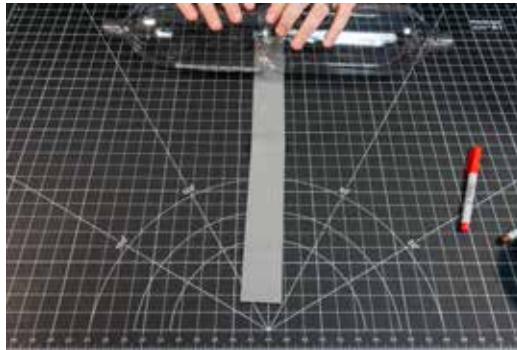

Step

8

Add the nose cone to finish your rocket.



Your First Water Rocket is Ready !

Adding the Elev8Eject - the parachute eject mechanism

We follow the same steps as above to create another fuselage but this time we will add the Elev8Eject - Parachute Eject Mechanism to our water rocket. The fuselage should be approx. 9.5 inches (24cm) tall from the top of the bottle threads to the base.

Additional Materials Required:

1. 1x Elev8Eject Parachute Eject Mechanism
2. 1x Eject Holder Shaft
3. 1x Clamp Nut
4. 1x Parachute
5. 1x Door latch components
6. 2x cable ties or twist ties
7. 1x short elastic cord (optional)
8. 1x Soda Bottle
9. Soldering Iron can be useful in this step but optional.

Preparing the Parachute Bay Door:

We will need to create a door for our parachute bay in the fuselage. Take an additional soda bottle, and remove the base. Trim the flat part of the bottle as illustrated in the images below.

Step

1

Remove the base

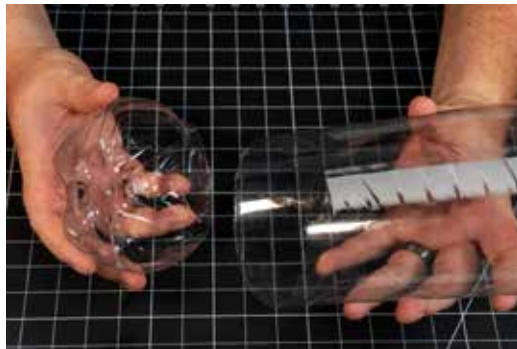

Step

2

Remove the top curved part, such that we have fairly cylindrical part left.



Step

3

Cut the cylinder open and lay it flat on a cutting mat

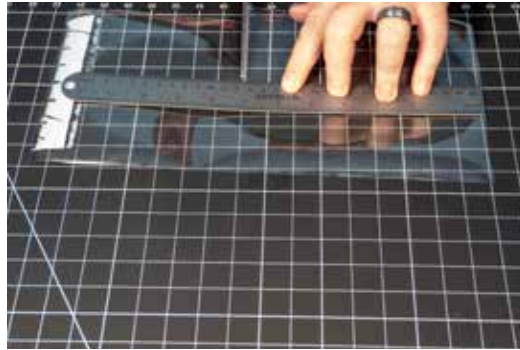

Step

4

Cut a 150mm long X 100mm high section, which will now act as our reverse spring door

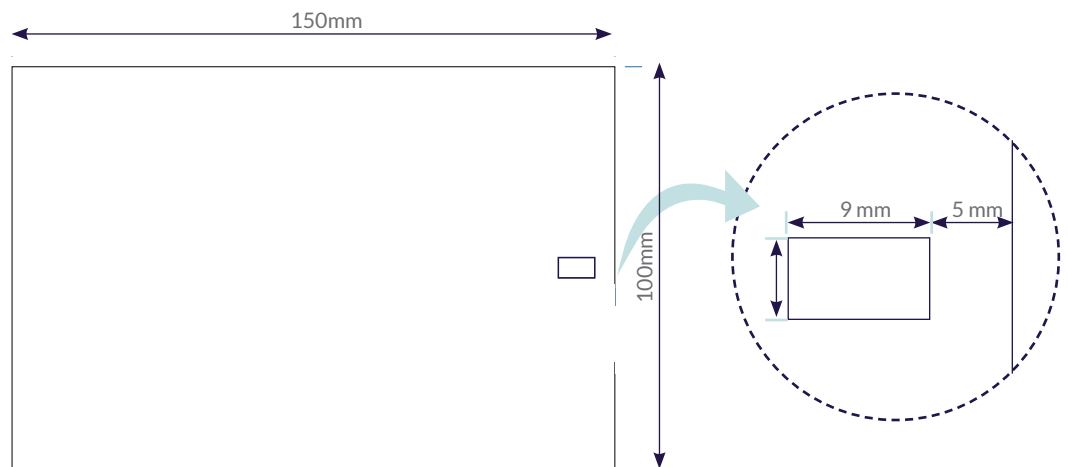

Step

5

Create a rectangular hole in the door as shown. A punch hole (included in the kit - 9mm X 5mm) or an XACTO knife can be used for cutting the hole.

Insert the door latch and clamp it.

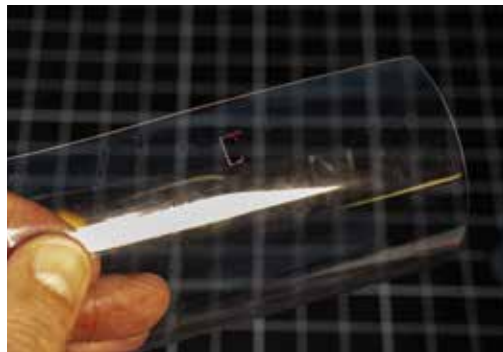

Parachute Bay Door is ready !

NOTTE: Each soda bottle can give us 2-3 doors. The size of the door may vary, but a good starting point is 150mm X 100mm door. The newly cut piece of PET will be used as a reverse spring door.

Installing Elev8ject (Parachute Eject Mechanism) :

Step

1

Install the Eject Holder Shaft in the bottle and tighten the clamp nut. Hand tightening the clamp nut is sufficient, over-tightening the clamp nut can lead to the bottle getting distorted.

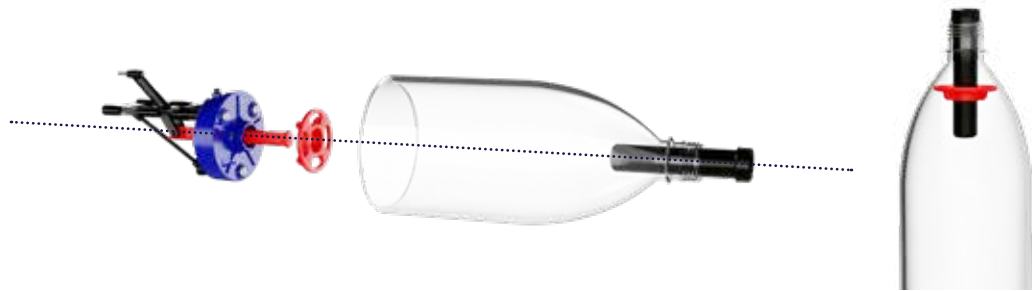

Step

2



Before installing the PEM (parachute eject mechanism) in the bottle, we need to test it. Hold the PEM straight with the plunger pointing up, turn on the system by pressing the ON/OFF button. If the LED power light doesn't come on or is weak, check and recharge the battery. Push the plunger down until it clicks and locks; the GREEN light should turn on at this stage. Tilt the PEM more than 60° to initialize the tilt switch, thus triggering the eject mechanism and releasing the plunger, which in turn pulls the lock slider upwards. Once the mechanism is tested for accurate operation, it is ready to be installed. Turn off the PEM and install it by screwing it on to the Eject Holder Shaft. Again – do not over-tighten, hand tight should be enough.

Step

3

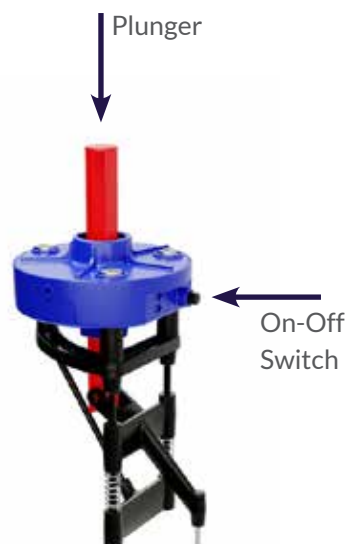

Arm PEM by pushing the plunger through the Eject Holder Shaft until it locks into position. Make sure the device is turned off at this time.

Step

4

Now find the pin on the lock slider and make a hole approximately 10mm X 5mm. The hole should be lined up with the pin as shown in the picture below.

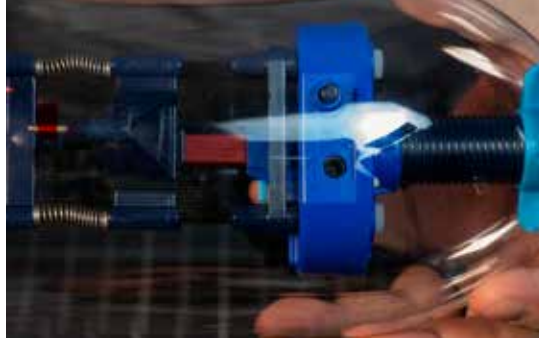

Step

5

You can use the door latch on the parachute door as a template to draw the rectangle, and use an XACTO knife or the hole punch (provided) to make the cut. Be careful while cutting.



Step

6

Once the square hole has been cut, you can release the lock slide, insert the door latch in the square hole and arm the mechanism again. This will enable you to hold the door in place for the next step.



Step

7

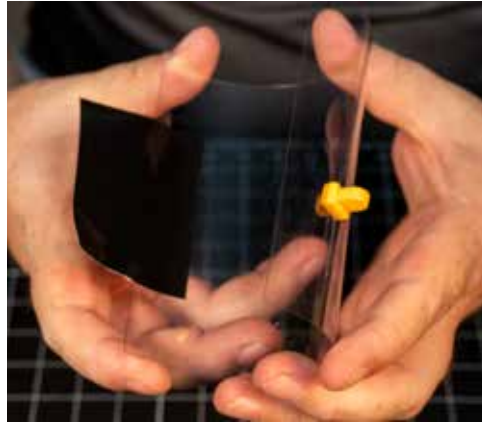

Apply a piece of duct tape as shown in the image to create a hinge.

Step

8

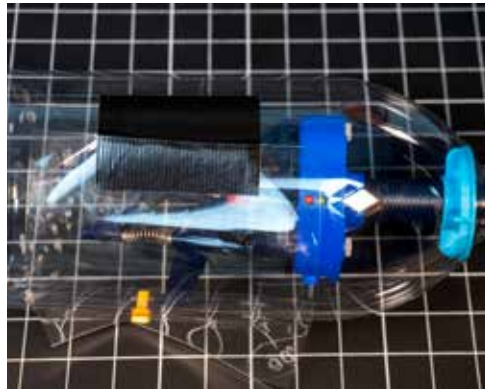

Finish installing the door with the PET door acting as a reverse spring.

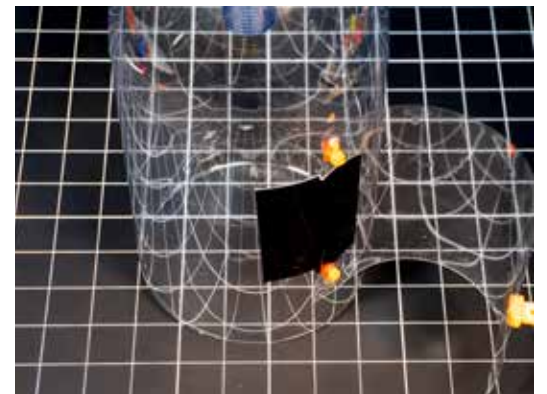

Optional

Additional (Optional) Step: You can use a soldering iron to create holes and use zip ties to create a hinge. This step enables you to use the fuselage over several launches and increase durability.

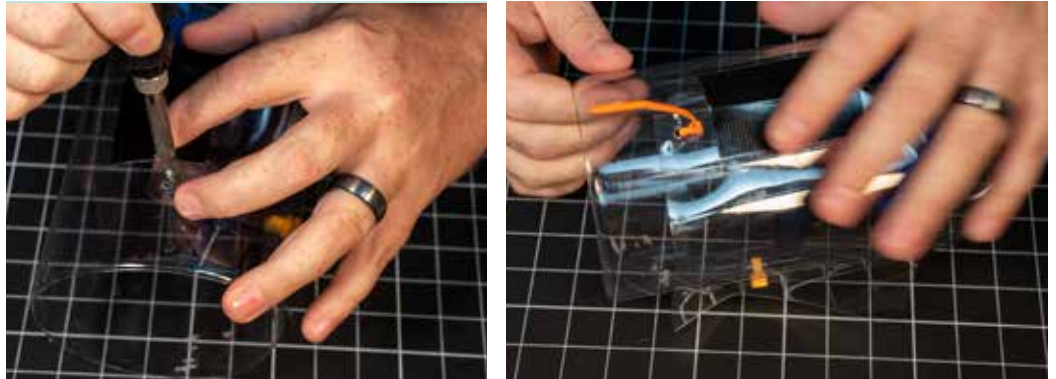

Finished product looks like this.

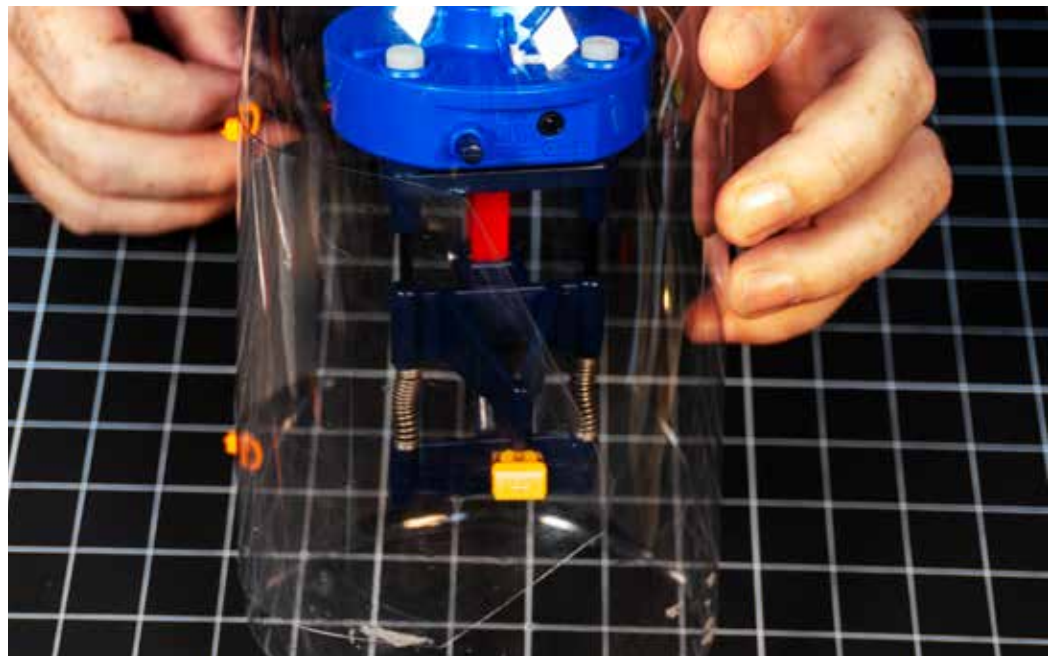

You can trim the sides of the eject bay door to make it more aerodynamic

Parachute Eject Mechanism (PEM) is now installed !

Attaching the Parachute:

The parachute is attached to the nose of the fuselage.

Step

1



Step

2

Grab the strings, and hold the parachute upside down, and create an even knot as shown in the picture below.

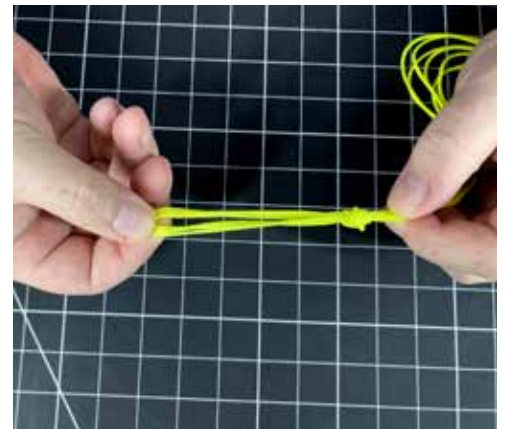
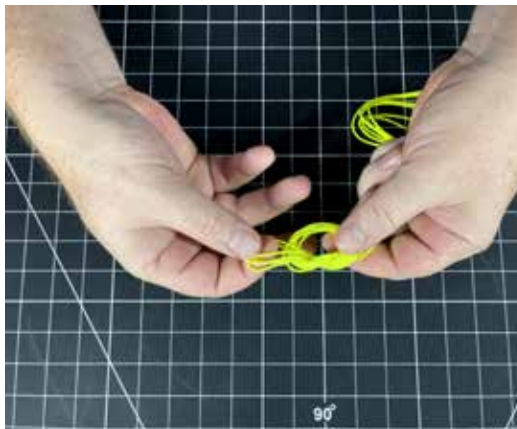
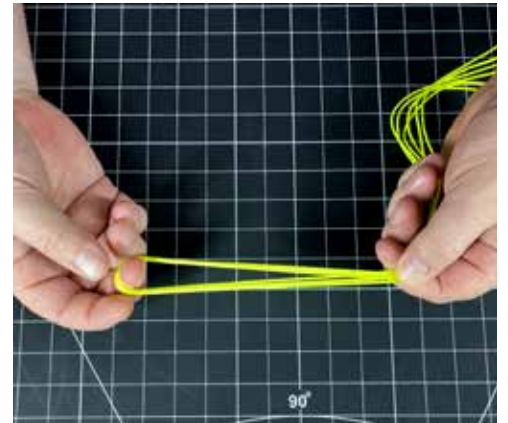
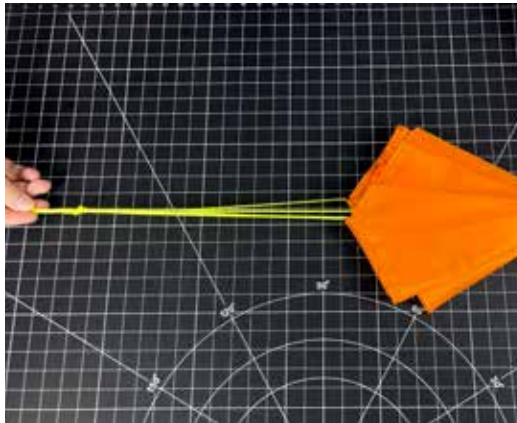

Step

3

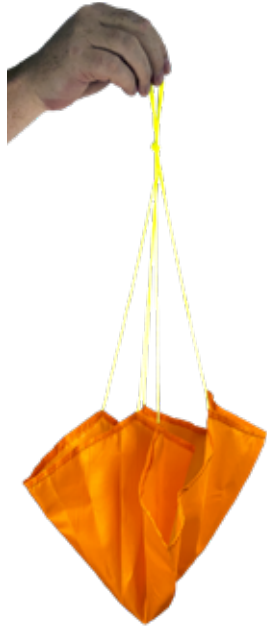

Use a zip tie, push it through the center of the knot and attach the parachute to the nose of the fuselage with the zip tie.

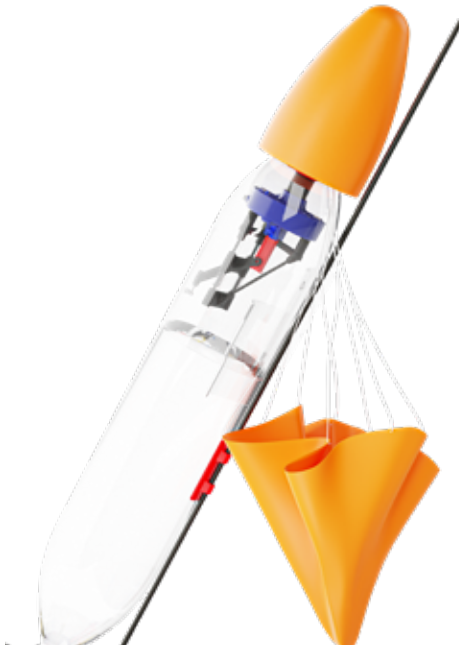

To build your own parachute, follow these steps:

http://www.uswaterrockets.com/construction_&_tutorials/Parachute/tutorial.htm

Parachute is attached and ready to be used !

Packing a Parachute:

When the parachute is deployed, it needs to unpack easily and fast, making the packing a very important step.

There are multiple ways to pack the parachute, we will share with you one of them, but with use and experience, your methods will evolve and we recommend experimenting and sharing the learnings with the community.

Step

1

We will fold the parachute 3 times:



Step

2

Then make a single loop of the strings around the folded parachute

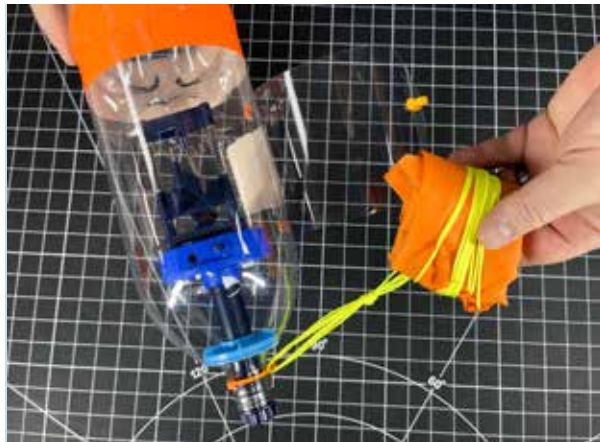

Step

3

Place the packed parachute between the fuselage and the door.



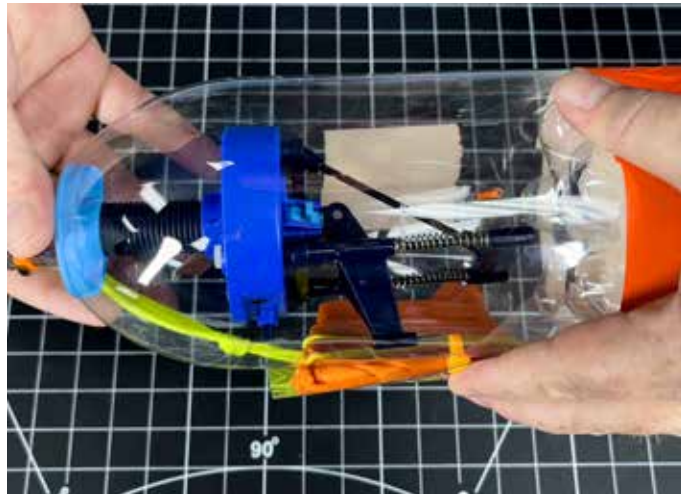
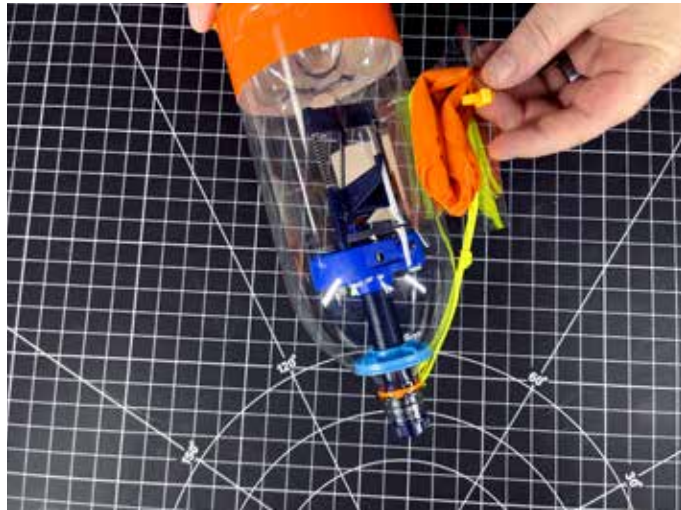

Step

4

Close the door, and arm the Elev8Eject to lock the door in place

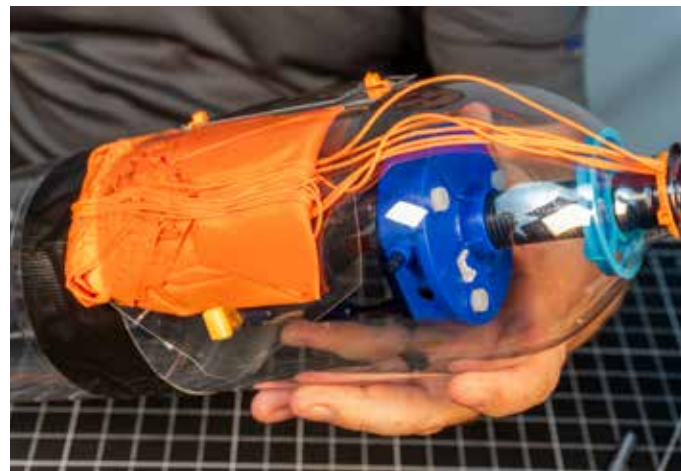

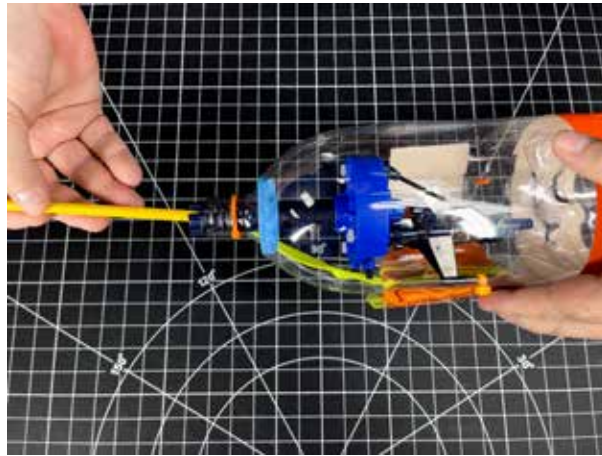

Step

5

Mount the nose cone and we are ready to go.

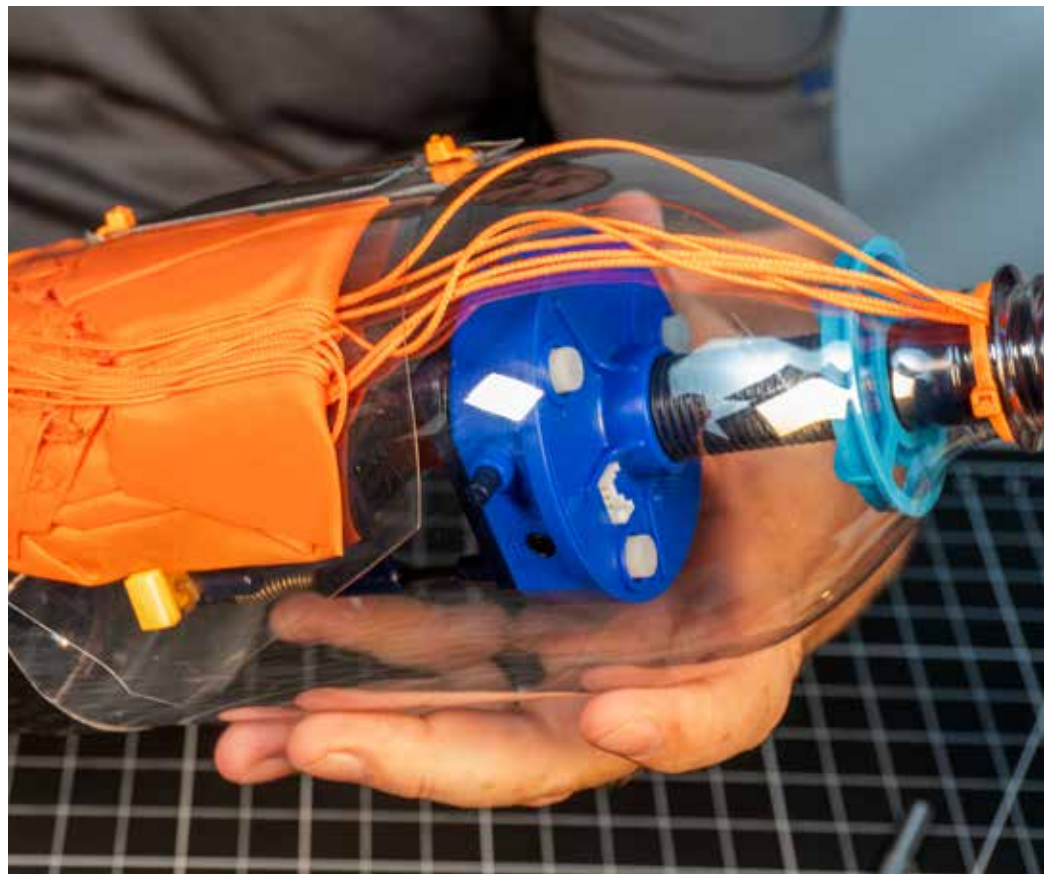

The rocket is almost ready to fly!

Just mount the nose cone and we are ready to go.

Installing HydroLaunch® Nose Cone

At only 82 grams, made of a high density Polyurethane foam, the HydroLaunch® Nose Cone makes your water rocket aerodynamic, and adds weight to the top of your rocket. It is designed to screw onto any standard PET Soda bottle enabling a fast turn around time on building and rebuilding your water rocket. .

Step

1

Screw the nose cone on the fuselage, and the Water Rocket is ready

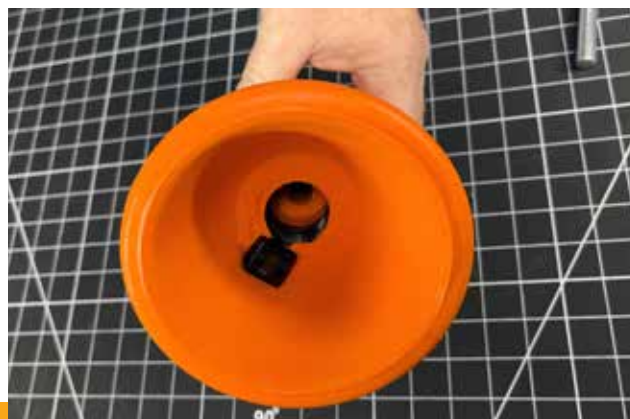

Step

2

For recording your rocket's flight data, you can install the LaunchTrak Altimeter into the nose cone as shown below.

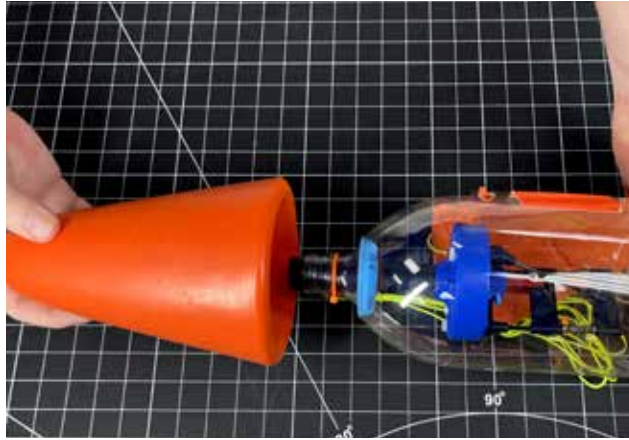

HydroLaunch® Nose Cone is installed !

Water Rocket Stability





Identifying the Center of Mass

Your rocket will spend most of its flight without any water in it, this makes it easy to find its center of mass by simply tying a string around the rocket and moving the suspension point along the rocket until you find the balance point. The closer this balance point to the nose cone, the more likely it is that your rocket will remain stable during flight.



Rocket A: Rocket with Parachute Eject installed



Rocket B: Rocket without Parachute Eject Installed

We need the rocket to be rendered as below with them hanging on a string. Rocket A has mass added to the fuselage, such as clay or the ejection mechanism and rocket B has no mass added.

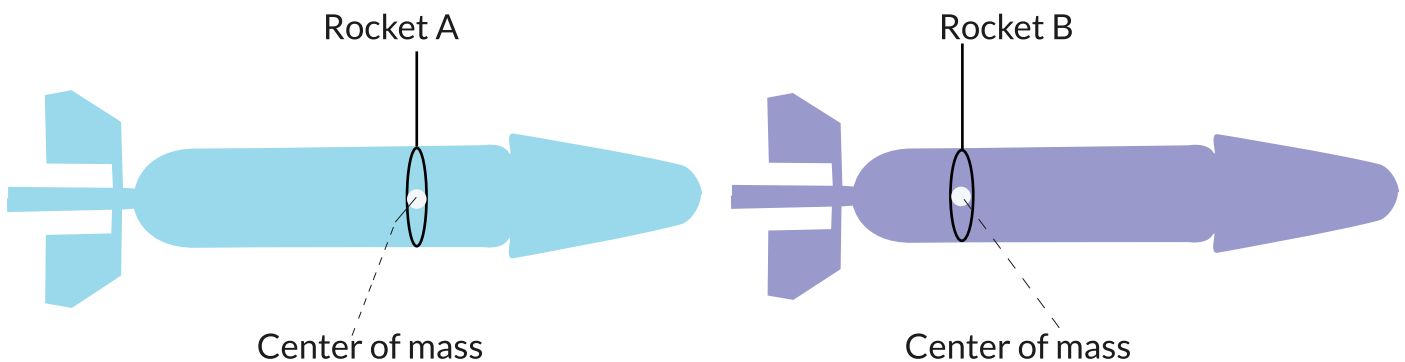

Center of Pressure

The forces which act on the rocket both when it is flying correctly, and when it is misaligned need exploration to truly understand the aerodynamic stability of the water rocket.

Let's consider two different rockets (let's call them Rocket A and Rocket B) which are the same shape and have the same fins, but which have different weight distributions resulting in different positions for their centres of mass.

In particular let's assume that Rocket B has its centre of mass much further back than Rocket A. The location of the center of mass is important because when outside forces act on the body of the rocket, the rocket will rotate about the center of mass.

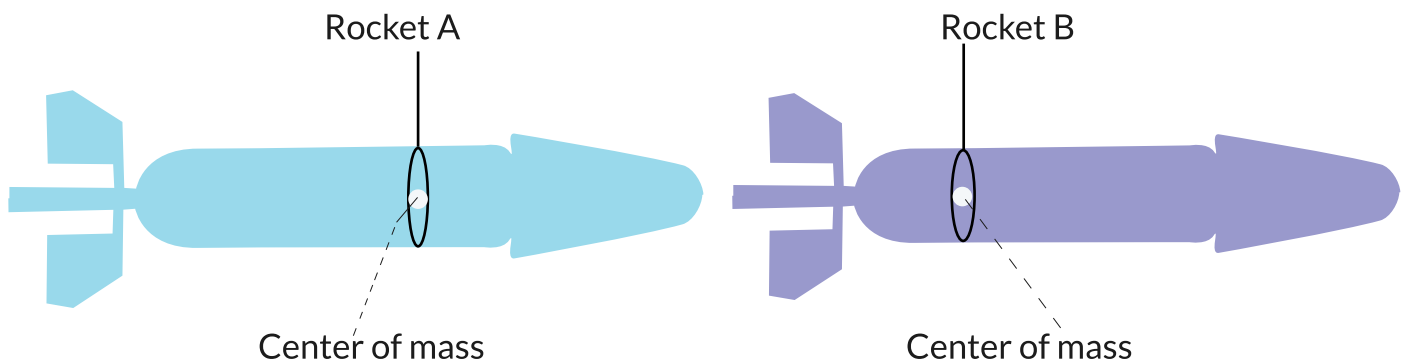

When you consider the forces on the rocket traveling in the direction of the blue arrow, there is mainly the drag force acting on the body of the rocket, and the thrust being generated by the expulsion of water and compressed air from the rocket engine.

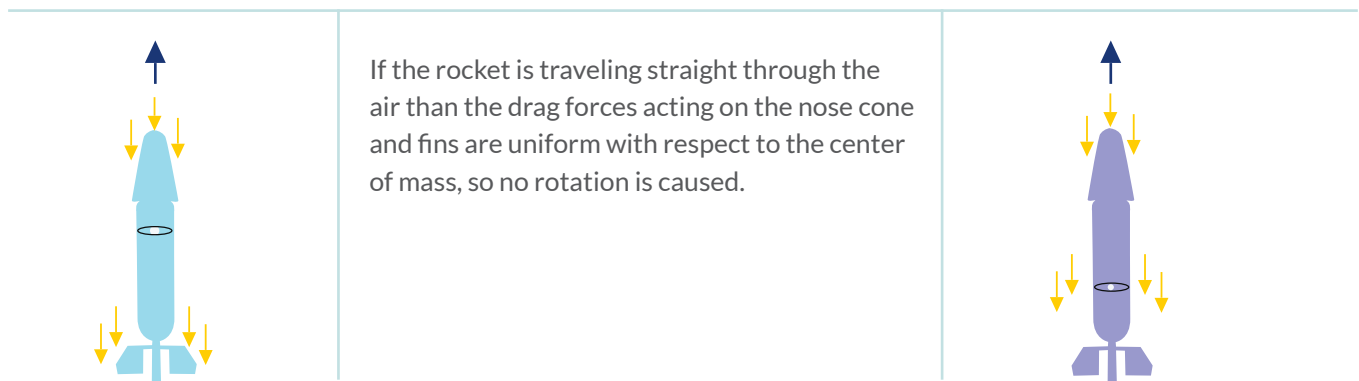

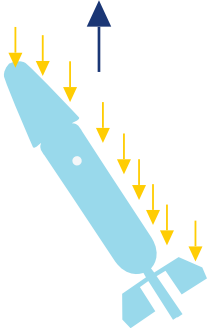
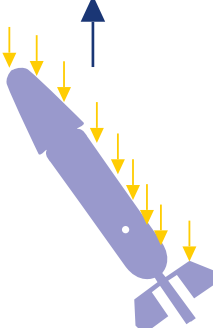
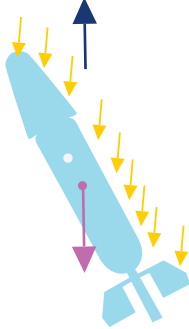
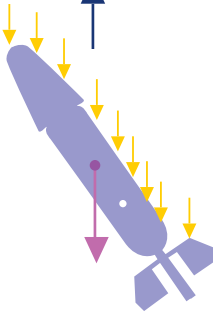
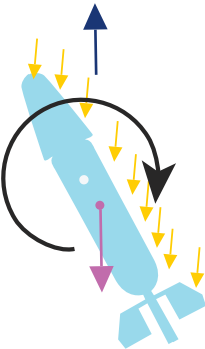
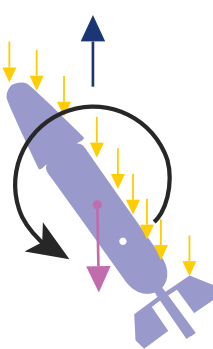
| | | |
|---|---|---|
|  | <p>If the rocket is traveling at an acute angle relative to the airflow, it will experience significant drag forces as more area is exposed to the oncoming airflow. The forces would act:</p> <ul style="list-style-type: none"> • On the nose of the rocket • Along the exposed sides, and • On the fins |  |
|  | <p>The forces on every part of the rocket are difficult to calculate or measure with precision. But, there is a point on the rocket which is the effective point of action of all the drag forces. This point is known as the center of pressure, and is marked with a PINK dot in the images.</p> <p>In the images, since both rockets are of identical shape, the center of pressure is at the same point, but the center of mass is different.</p> |  |
|  | <p>For Rocket A, the center of mass is higher than the center of pressure, so the extra drag forces act more on the back end of the rocket and tend to push it back in line. Technically, the drag forces exert a torque which acts about the center of mass to restore optimal flight orientation.</p> <p>For Rocket B, the center of mass lies behind the center of pressure, so the drag forces act more on the front end of the rocket and tend to 'push it out of line' causing it to be unstable.</p> |  |

Thus, it is the relative positions of the center of mass, and the center of pressure that determines whether a rocket is aerodynamically stable or unstable. With the center of mass being ahead of center of pressure resulting in a more stable flight.

Estimating the position of the Center of Pressure

Estimating the position of the centre of pressure turns out to be rather hard to do accurately, but there is a simple technique which you can use to make a rough estimate of its position. This involves making a flat 'silhouette' of your rocket on rigid poster board.



Once you have created the flat silhouette of your rocket, you can now estimate the center of pressure of your rocket by hanging the silhouette from a string and finding the center of mass of the silhouette.

As the photograph shows, the centre of mass of the silhouette is much further back along the rocket body than the centre of mass of the rocket itself. To the extent that the centre of mass of the silhouette really is a good estimator for the centre of pressure of the rocket.

For a more mathematical approach, a simplified method for determining Center of Pressure can be found here - <https://www.grc.nasa.gov/www/k-12/rocket/rktcp.html>

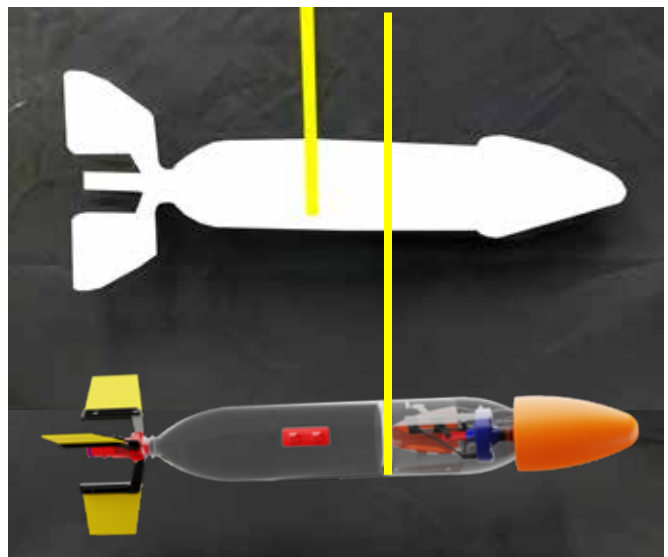

Preparing for flight





Some things to consider while preparing for your water rocket flight.

Weight of the Empty Rocket:

This is the weight of the rocket without the water in it. This will be the part of the rocket which makes the whole journey. Using an electronic scales, it is not too difficult to measure to the nearest whole number in grams.

Engine Volume:

The total volume is likely to be very close to the volume stated on the label, but is usually a little more. Fill the bottle with water to the top, and then use a graduated cylinder to measure the actual volume.

Fuel Volume (Water Volume):

This is something you can easily customize and which makes a big difference to the performance. A good starting point is generally to fill with about one quarter water. The optimum filling depends on a number of factors, but is generally in the range from 30% to 50%. One thing you can do before you head outside to launch, is to mark the side of the rocket with tape to show where the 20% or 25% mark is; remember you will generally be filling the rocket when it is upside down so this mark will generally be in a non-obvious position.

Launch Angle:

If the rocket were an un-powered projectile with no aerodynamic drag, then the angle to give the greatest range would be 45°. However, this is not the case for a water rocket, although the optimum angle is unlikely to be very far from 45°. Since the rocket's mass changes drastically during the first fraction of a second into flight, you will get a more optimum range from your rocket by launching it slightly more vertically.

Launch Pressure:

Increasing the pressure increases the stored energy at launch, which increases the maximum speed attained by the rocket, and this increases the launch range, flight time, and maximum height. However, you will find that increasing the launch pressure by a given amount

(a) becomes harder to do and

(b) makes less and less difference.

The reason is aerodynamic drag. This will increase rapidly with increasing launch speed and 'steals' all the kinetic energy imparted to the rocket. If you have a launch pressure of 5 atmospheres (75 psi) and are still looking for improvements, then its better to try reducing drag rather than increasing the pressure further. You should never increase the pressure beyond 90psi.

To get the most out of your water rocket experience, we suggest you prepare a log sheet to collect data from your launches. Fixing multiple variables and altering only one at a time enables a better learning experience. For example, fixing the amount of water, pressure, rocket weight and launch angle, and only changing the nozzle (insert) size will enable you to observe the rocket's performance with different nozzle sizes.

An example sheet is attached for your reference.

| HYDROLAUNCH® WATER ROCKET LOG SHEET | | | | | | | |
|--|------|--|--|---------------------------|--|--|--|
| DATE | TIME | | | ROCKET IDENTIFIER OR NAME | | | |
| | | | | | | | |
| LAUNCH PARAMETERS | | | | | | | |
| Launch Number | | | | | | | |
| Rocket Mass | | | | | | | |
| Engine Volume | | | | | | | |
| Fuel Volume | | | | | | | |
| Launch Mass | | | | | | | |
| Launch Angle | | | | | | | |
| Launch Pressure | | | | | | | |
| Nozzle Size | | | | | | | |
| RECORDED DATA | | | | | | | |
| Horizontal Distance | | | | | | | |
| Altitude | | | | | | | |
| Time of Flight | | | | | | | |
| Parachute Deployed? | | | | | | | |
| Other Data | | | | | | | |

Preparation Checklist:

- HydroLaunch® Water Rocket Launcher kit
- Water Rockets
- Launch Rod and Launch Guide
- Bike Pump with a pressure gauge
- Safety cones for marking launch site
- Water
- Graduated Cylinder for measuring fuel quantity.
- Log Sheet
- Safety Goggles
- LaunchTrack
- Pencil

NOTE : Make notes of more visible observations that are not quantifiable but important for discussions with your team mates or students to understand better the underlying physics and mathematics of motion and rocket launches.

Launching

HydroLaunch® Water Rockets, like all rockets, model or professional, are launched from a safe distance. The only difference is that instead of using an electric system, we use a pneumatic launch system for both safety and simplicity.





Launch Area & Safety:

Choose a large field away from power lines, tall trees and low-flying aircraft.

Always follow the NAR Model Rocket Safety Code, and the safety guidelines mentioned in this document.

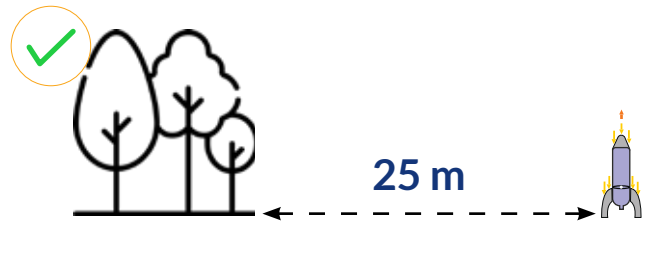
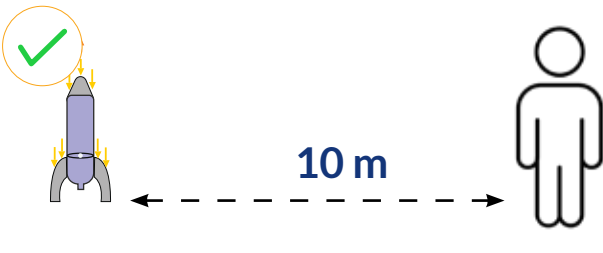
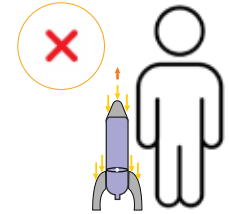
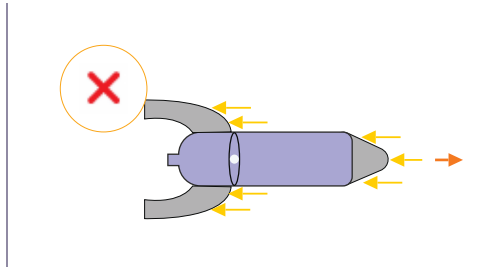

Preparing the Rocket & Launcher:

Step

1



You can set up the HydroLaunch® Water Rocket Launcher on the ground or on a table. Make sure the ground is free of any dirt that might get inside the launcher. The ingress of dust into the rocket launcher inevitably leads to the failure of the check-valve.

Step

2



Connect the pneumatic line to the Push-to-Connect bulkhead connector on the faceplate

Step

3

Run the line to the bike pump, and connect the line to the bike pump. Make sure the bike pump is at least 10 meters away.

Step

4

Apply heavy duty mounting tape on the back of the Launch Guide (if not already applied).

Step

5

Unscrew the nozzle from the rocket (make sure the Elev8Eject - parachute eject mechanism) is turned off.



Step

6

Fill the rocket engine with a requisite amount of rocket fuel (water) by using a graduated measuring cup

Step

7

Choose the nozzle insert size for your rocket, insert it into the nozzle and screw it back on the engine.



Step

8

Take out all the fins, and DO NOT attach the launch guide to the bottle at this time. We will install it once the rocket is loaded on to the launcher.



The Rocket & Launcher is ready !

■ Rocket on the Launcher:

The HydroLaunch® Water Rocket Launcher is designed to launch from a safe distance, and since it is pneumatically controlled, the air (pneumatic) line can be very long. Please note, the longer the air line, the longer it takes for the launch to trigger, since it takes longer for the air to travel back from the piston to trigger the launch.

The tilt mechanism on the HydroLaunch® Water Rocket Launcher allows you to load the water rocket without spilling water. It also allows you to set an angle of launch from 0° to 90° from the vertical. It is not recommended to launch at more than 45° from the vertical.

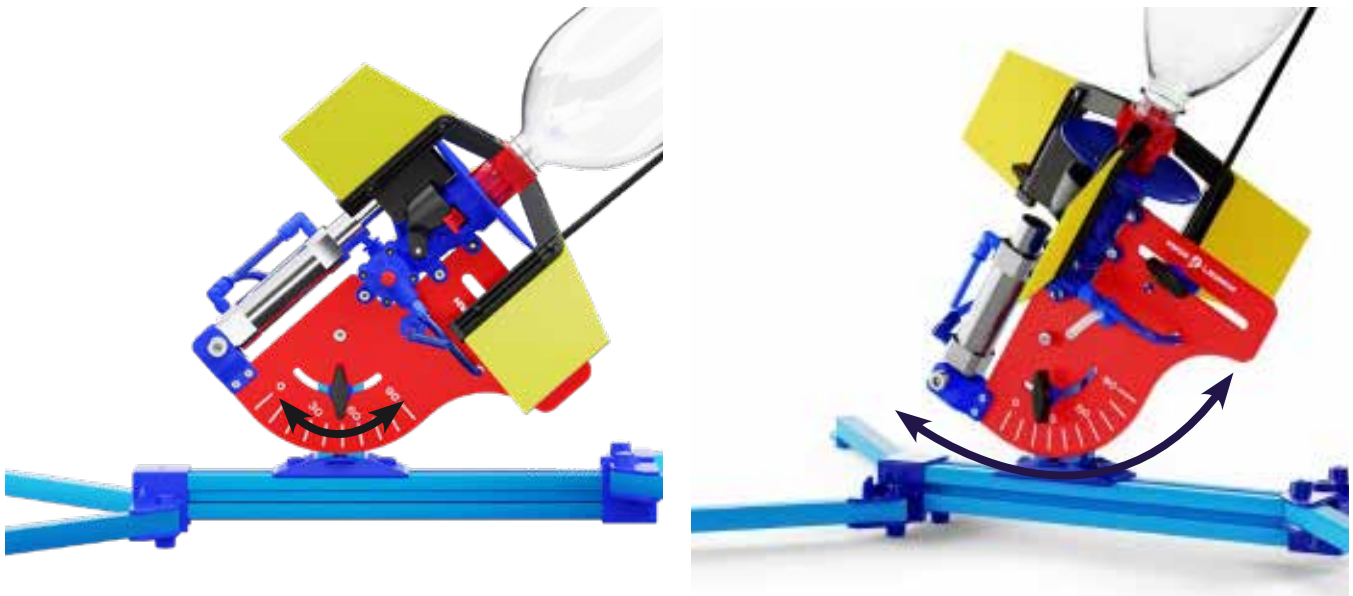

Step

1

Rotate the rocket such that all the fins can be installed without hitting the faceplate or the Lock Catch.

Step

2

Once the fins are installed, loosen the launch rod holder and insert the launch rod into the holder.

Step

3

Ensure the rod is about 5mm from the edge of the engine bottle.

Step

4

Tighten the launch rod holder in place.

Step

5

Remove the sticky covering from the mounting tape on the launch guide and slide the launch guide down the launch rod until it is at the top of the engine bottle just below the duct tape.

Step

6

Press the launch guide firmly to the engine bottle ensuring the mounting tape sticks well.



Pressurizing the Rocket:

1. Make sure the launchrange is clear of any passerby, and all the students and adults are at least 10 meters away from the launcher.
2. Ensure the pneumatic lines are all inserted in to the push-to-connect attachments properly to avoid any leaks.
3. Make sure the PEM is turned on and armed if in use. This needs to be done just before starting to pressurize.
4. Using the bike pump, pressurize the rocket to the desired pressure (not exceeding 90psi).

Launching the rocket :

1. Once the rocket is pressurized, make one last loud announcement to let everyone know that you are about to launch a water rocket.
2. Hold down the launch trigger, you will hear the sound of air releasing from the launch trigger, and depending on the length of your air line, the rocket will be released by the launcher momentarily.

Recovery:

1. Once the rocket has fully touched the ground, it is now safe to recover the rocket.
2. If you are recording data for experimentation, it is a good idea at this time to measure the horizontal distance between the launcher and the rocket.
3. Record data from the LaunchTrak on the log sheet.

Launch | Recover | Repeat

Model Rocket Safety Code:

Though not every parameter from the NAR Model Rocket Safety Code applies to water rocketry, most of them provide valuable guidelines to a safe rocketry experience.

<https://www.nar.org/safety-information/model-rocket-safety-code/>

Troubleshooting



Issues with the Rocket:

1. Leaking Water and/or Air out of the nozzle — There is a nozzle insert with a garden hose washer on it inserted between the nozzle and the soda bottle. If there is a leak, check the following:
 - Check if the nozzle insert has a washer on it, and is present inside the nozzle
 - Make sure the nozzle is tightly screwed on the soda bottle
2. Rocket “Flutters” After Take-Off —
 - Check the fins and make sure they are not bent. Replace fins if needed.
 - To stabilize a rocket, add more weight to the top. Usually modeling clay is a good option.

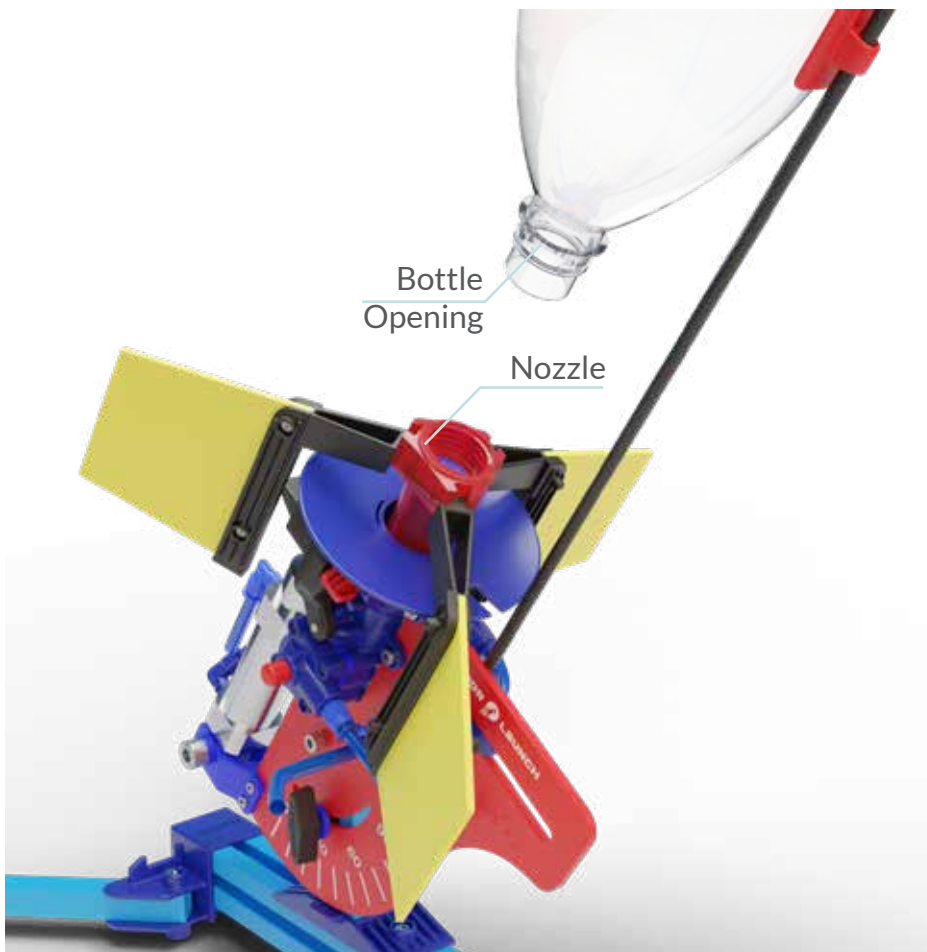

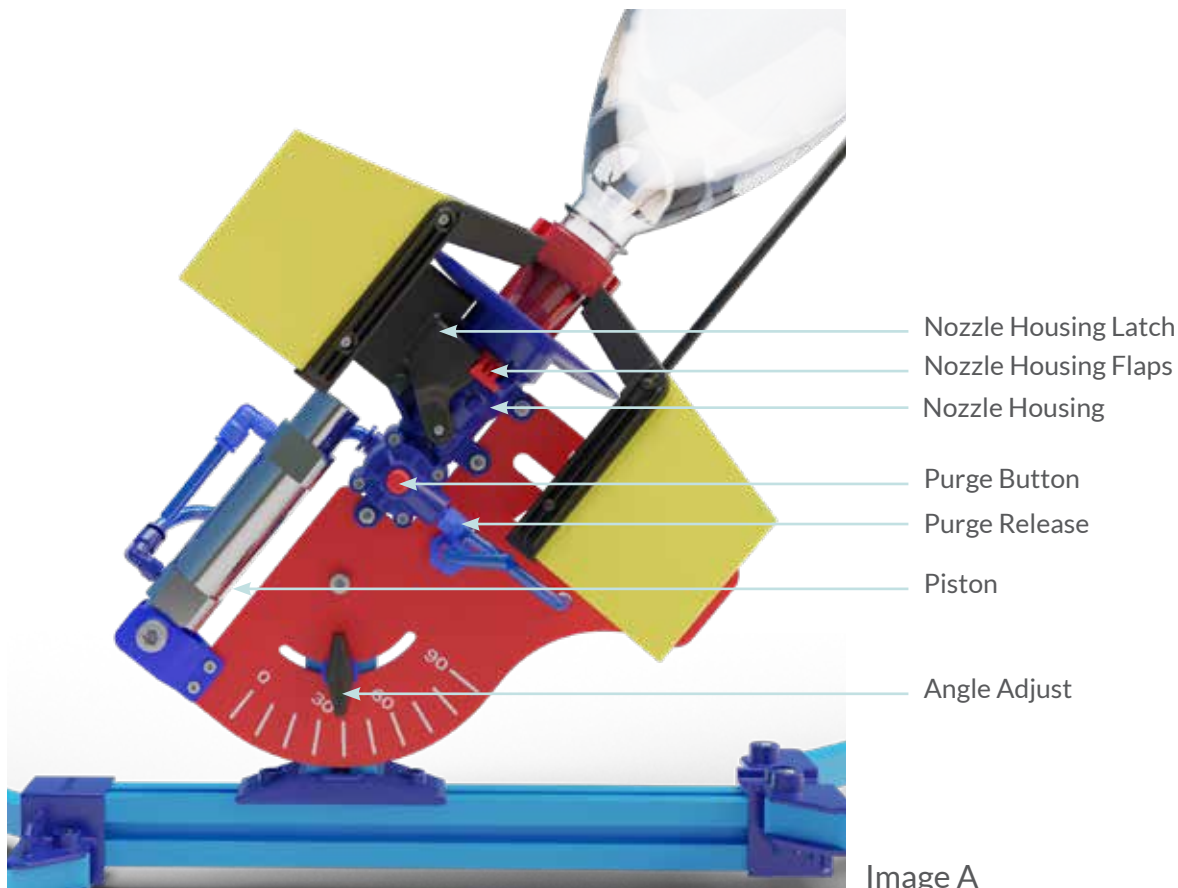

Image A

Issues with the HydroLaunch®

Water Rocket Launcher :

1. Water and/or Air leaking from the top of the Nozzle Housing – The rocket Nozzle has an O-Ring on it that creates the seal with the nozzle housing on the launcher.
 - Move the O-ring back into the groove.
 - If the O-Ring feels loose, then replace it.
2. Leaking From Emergency Purge Button –
 - Press the Purge Button a few times to try to release the internal mechanism. If it still leaks, contact us.
3. Leaking From check valve on the Nozzle Housing (on opposite side of Purge Button):
 - Will most likely be due to cracks in the nozzle housing, contact us.
4. When using the bike pump, air does not go into the bottle and pressure does not hold :
 - Make sure the arrow on the bike pump valve is pointed into the bike pump attachment (as seen below in the photo C).
 - If the bike pump is attached correctly, check along the hose to see if there are any leaks. If the leak is near an attachment, the hose can be cut and reattached. If not, contact us for a replacement.
5. Air is leaking out of the trigger release when air is pumped.
 - Try pressing down on the trigger a few times to get the trigger pin to pop-up. If this does not work, contact us.

6. When The Rocket Is Ready to Launch, Water Comes Out of the Trigger Air Release When the Trigger Is Pressed :

- The check valve has failed on the launcher. Possible reasons are dirt in the pressure chamber. Contact us for repair / replacement.

7. Launch triggers prematurely: If the rocket launches while you are pressurizing it without pressing the launch trigger

- The piston holding the rocket steady during pressurizing is leaking pressure - make sure the blue tubes are pushed all the way in and cannot be pulled out from any of the connectors.
- The piston assembly has failed. Contact us for repair/replacement.

Trigger Air Pin

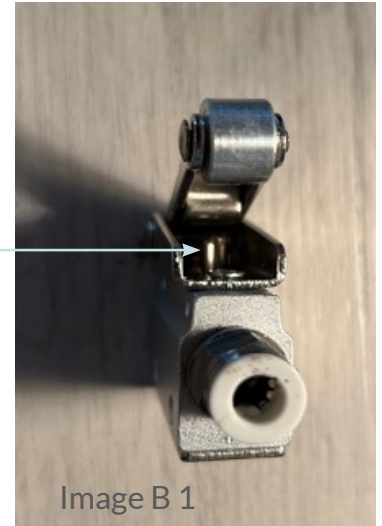

Trigger Air Release

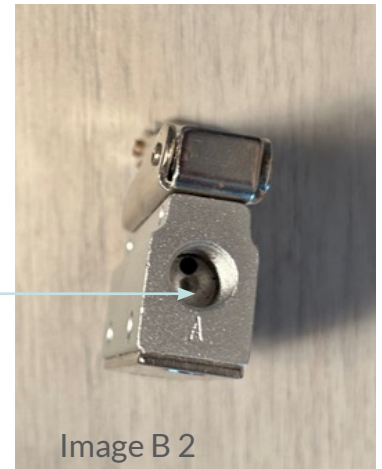

Image C

Bibliography

- https://www.npl.co.uk/skills-learning/outreach/water-rockets/wr_booklet_print
- <https://www.nar.org/>
- <https://www.grc.nasa.gov/www/k-12/rocket/rktbot.html>
- <http://www.aircommandrockets.com/>
- <https://www.npl.co.uk/water-rockets>
- <https://www.grc.nasa.gov/www/k-12/rocket/rktcp.html>

the \mathbb{R}^n space. The \mathbb{R}^n space is a vector space over the real numbers, and the \mathbb{R}^n space is a vector space over the real numbers.

The \mathbb{R}^n space is a vector space over the real numbers, and the \mathbb{R}^n space is a vector space over the real numbers.

The \mathbb{R}^n space is a vector space over the real numbers, and the \mathbb{R}^n space is a vector space over the real numbers.

The \mathbb{R}^n space is a vector space over the real numbers, and the \mathbb{R}^n space is a vector space over the real numbers.

The \mathbb{R}^n space is a vector space over the real numbers, and the \mathbb{R}^n space is a vector space over the real numbers.

The \mathbb{R}^n space is a vector space over the real numbers, and the \mathbb{R}^n space is a vector space over the real numbers.

The \mathbb{R}^n space is a vector space over the real numbers, and the \mathbb{R}^n space is a vector space over the real numbers.

The \mathbb{R}^n space is a vector space over the real numbers, and the \mathbb{R}^n space is a vector space over the real numbers.

The \mathbb{R}^n space is a vector space over the real numbers, and the \mathbb{R}^n space is a vector space over the real numbers.

The \mathbb{R}^n space is a vector space over the real numbers, and the \mathbb{R}^n space is a vector space over the real numbers.

The \mathbb{R}^n space is a vector space over the real numbers, and the \mathbb{R}^n space is a vector space over the real numbers.